

**Somali Democratic Republic
Ministry of Agriculture**

Farahaane Irrigation Rehabilitation Project

Topographical and Cadastral Survey Report

**Sir M MacDonald & Partners Ltd
Demeter House, Station Road, Cambridge CB1 2RS England**

December 1987

CONTENTS

		Page Nr
CHAPTER 1	INTRODUCTION	1
CHAPTER 2	EXISTING DETAILED TOPOGRAPHIC DATA	2
CHAPTER 3	TOPOGRAPHIC SURVEY FIELDWORK	
	3.1 Level Control	3
	3.2 Base Mapping	6
	3.3 Beacon Placement	6
	3.4 Cross-Sections of Existing Canals	8
	3.5 Proposed Drain and New Canal Alignments	8
	3.6 Additional Levelling Work	8
CHAPTER 4	TRIAL CADASTRAL SURVEY	
	4.1 Introduction	9
	4.2 Methodology	9
	4.3 Farmer Relations and Participation	11
	4.4 Findings of the Cadastral Survey	12
	4.5 Potential Impacts of the Project	18
	4.6 Conclusions	22
APPENDIX A	BENCH MARK REFERENCE SHEETS	A-1
APPENDIX B	RECOMMENDED METHODOLOGY FOR A CADASTRAL SURVEY	B-1
APPENDIX C	NOTES ON MAPPING REQUIREMENT FOR ON-GOING PROJECT WORK	C-1
APPENDIX D	LOGISTICAL REQUIREMENTS FOR THE CADASTRAL SURVEY	D-1
REFERENCES		R-1

Bound Separately - 1 completed set of farm plot registration cards for
the trial area.

LIST OF TABLES

	Page Nr	
3.1	Bench Mark List	4
3.2	Beacon Levels	7
4.1	Size Distribution of Smallholder Farm Plots	15
4.2	The Number of Plots Held by Each Household	16
4.3	Compensation Rates for Trees Payable as the Genale Bulo Mareta Project	19

LIST OF FIGURES

	Following Page Nr	
2.1	Index to 1:10 000 Air Photography	2
2.2	Index to existing 1:10 000 Mapping	2
2.3	Index to existing 1:2 000 Mapping	2
3.1	Levelling Control Diagram	3
4.1	Farm Plot Registration Card	9
4.2	Map of Registered Large Farms	13
B1	Example Plot Area Calculation sheet	B-8

Map Pocket - 2 sheets at 1:2 000 cadastral farm plot layout map

1 INTRODUCTION

Both the Cadastre and topographic survey work were carried out as part of the data collection stage of the Farahaane Irrigation Rehabilitation Project under an agreement between the Ministry of Agriculture of the Somali Democratic Republic and Sir M MacDonald & Partners Ltd.

The aim of the surveying work was to provide adequate appropriate information to permit the preparation of detailed designs and contract documents to be drawn up for international tendering. The overall aim of the project is to rehabilitate a net area of about 4 700 ha, emphasis being placed upon the provision of drainage, improved roads and the remodelling of existing canals, along with the provision of silt free water throughout the year.

The field team was operational in Somalia between 28 September 1987 and 2 December 1987 and comprised the following staff:-

Mr W Pemberton	-	Project Manager
Mr P Warner	-	Irrigation Team Leader
Mr A Bird	-	Survey/Cadastre Specialist
Miss J Hunter	-	Irrigation/Survey Engineer
Mr E Sephton	-	Barrage Specialist
Mr M Jama	-	Farming System Adviser/Rural Sociologist
Mr Hassan Bashir Ibrahim	-	Surveyor

In addition, two counterpart staff were seconded to the team from the Ministry of Agriculture:-

Mr Ali Aidid Hassan	-	Agriculturalist
Mr Ahmed Haji Nuur	-	Irrigation Engineer

The field work was slowed by the untypical rainfall pattern of 1987, the der rains falling in November some two months later than normal. This made access to the site difficult and at times meant that cadastral survey work was also hampered by the non-availability of farmers in their fields due to localised flooding. The river was in flood for all but the last few days of fieldwork with the result that detailed topographic levelling work in the river bed upstream and downstream of the barrages has been delayed until late January, by when it is hoped the river level will be low enough to carry this out.

2 EXISTING DETAILED TOPOGRAPHIC DATA

Existing data coverage of the project area is shown on the accompanying maps, Figures 2.1, 2.2 and 2.3. The work appears to have been carried out by GeoSurvey International Ltd, whose East African operations are now trading as Photomap Kenya Limited, P O Box 43805, Nairobi, Kenya (Tel 500228, Telex 22287), the UK parent company having ceased operations.

The following existing data was borrowed from the Ministry of Agriculture, Mogadishu and used for the project:-

- a) One set of 1:10 000 uncontrolled bromide contact prints of air photography flown in March 1985 by GeoSurvey International. Their successors, Photomap Kenya, still retain the original film roll negatives. It should be noted that the area west of the Bokore canal including the Farahaane to Falkeerow road and Falkeerow barrage are outside the coverage. An index is shown in Figure 2.1.
- b) Six part sheets of 1:10 000 topographic mapping with 1 m contours plotted from the 1:10 000 1985 air photography. It shows many TP's (assumed to be traverse points) but no control details are known, however it seems likely that these points were EDM traversed and height control was probably carried out using trigometric levelling techniques. The North West and South East corners of the project area are excluded, as are the Gayweerow and Falkeerow barrage sites and the areas surrounding them. A sheet layout and index is shown in Figure 2.2.
- c) Seven 1:2 500 nominal scale enlarged bromide paper prints of alternate frames of the uncontrolled 1:10 000 1985 air photography covering the trial area (see Figure 2.3 for its location). These are unrectified, uncontrolled and are not mosaiced. Additionally, being bromide prints, they are not in a form that can be reproduced to provide field copies for cadastral work. They are also to a different scale than the detailed topographic mapping.
- d) Eleven part sheets of 1:2 000 topographic mapping of the TAMS selected trial area covering approximately 800 ha and showing 0.25 m contours. The sheet layout is shown in Figure 2.3. These sheets appear to be replots and are not enlargements of the 1:10 000 mapping.

No details regarding plan and height control were available for any of this work. The only identifiable level features were the TP points marked on the mapping, three of which were found intact in the field and were tied to. There is no list of levelled points with values or location diagrams for any of the TAMS or GeoSurvey work.

Figure 2.1
Index to 1:10,000 Air Photography

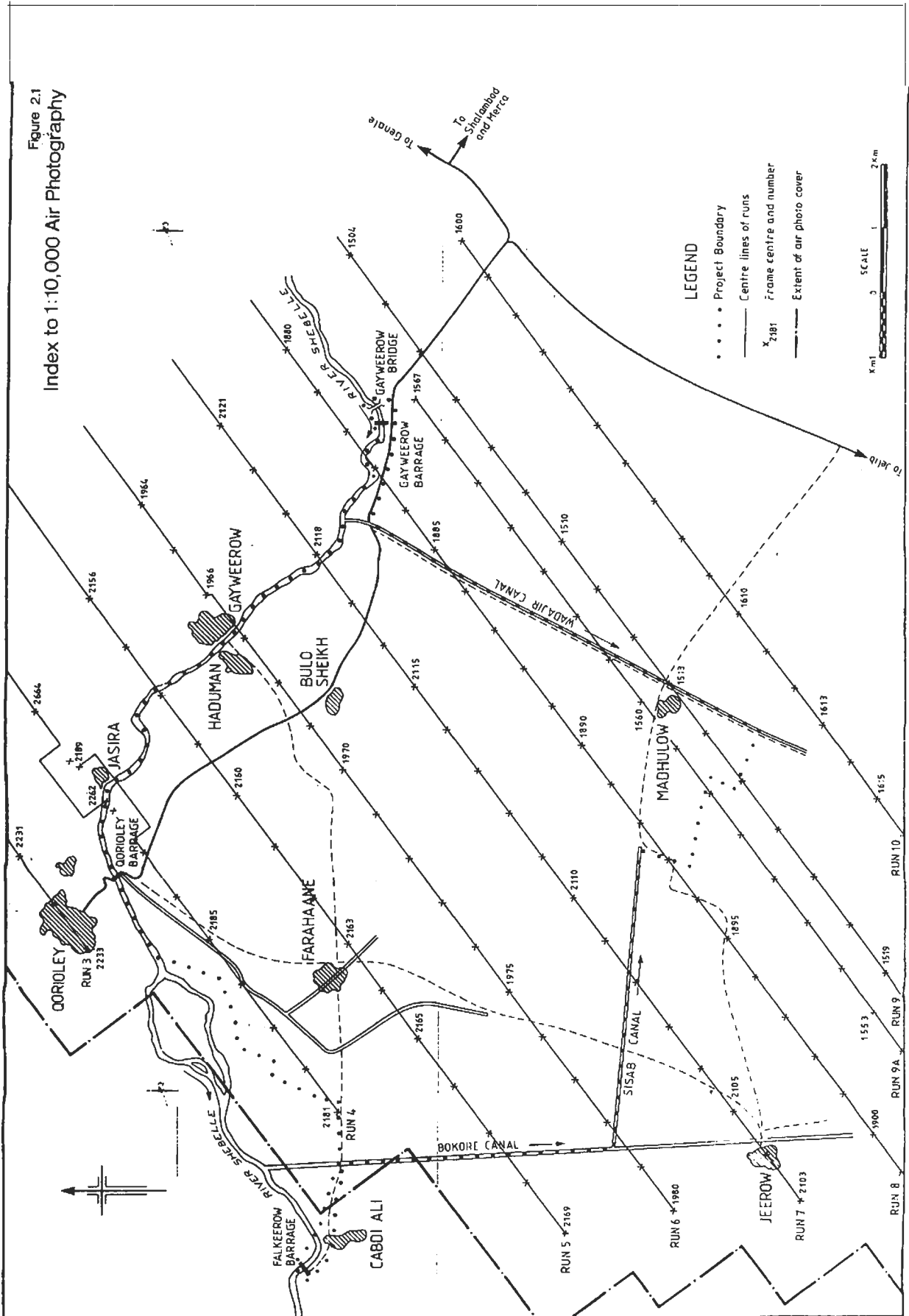

Figure 2.2
Index of Existing 1:10,000 Mapping

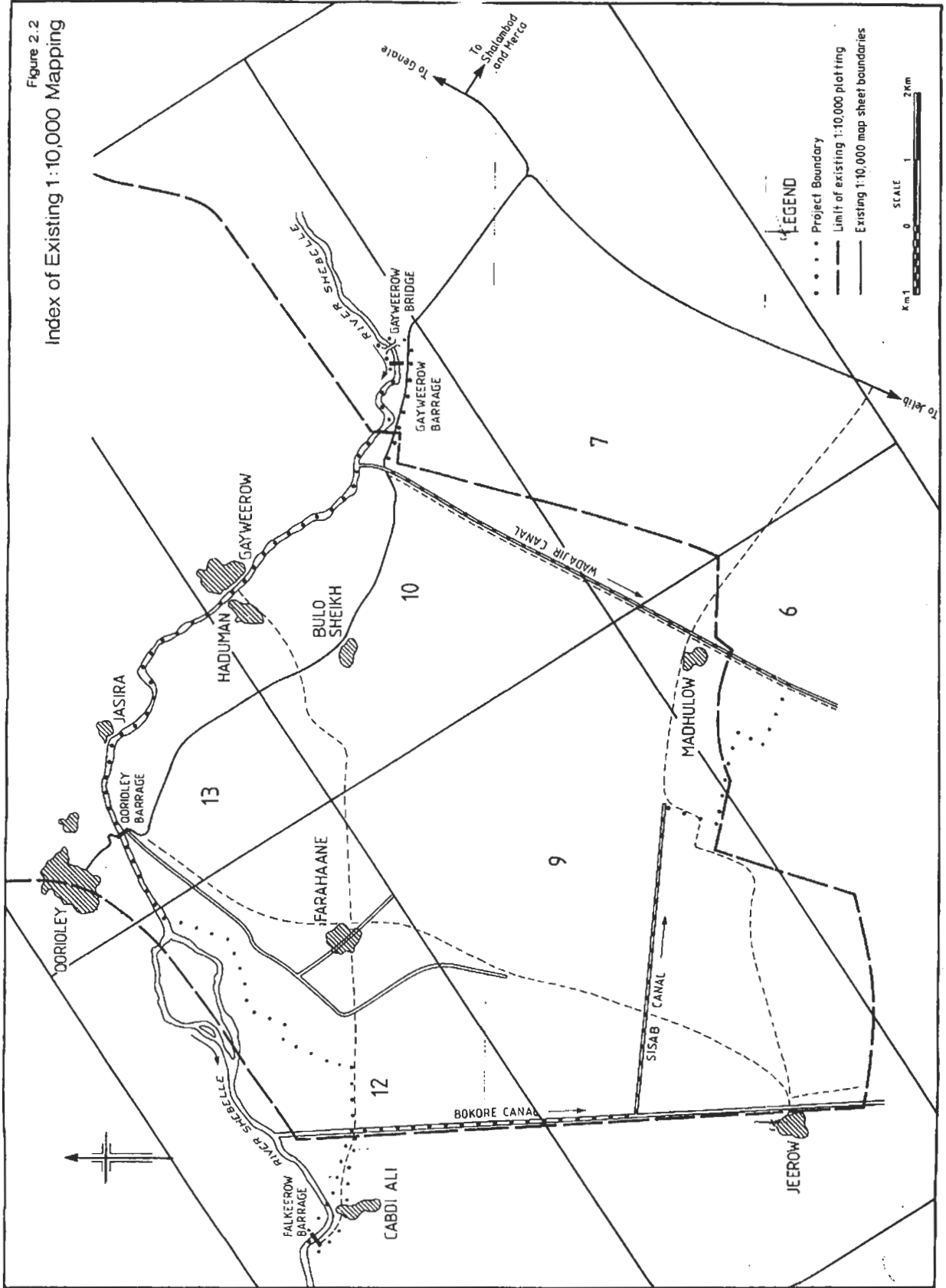
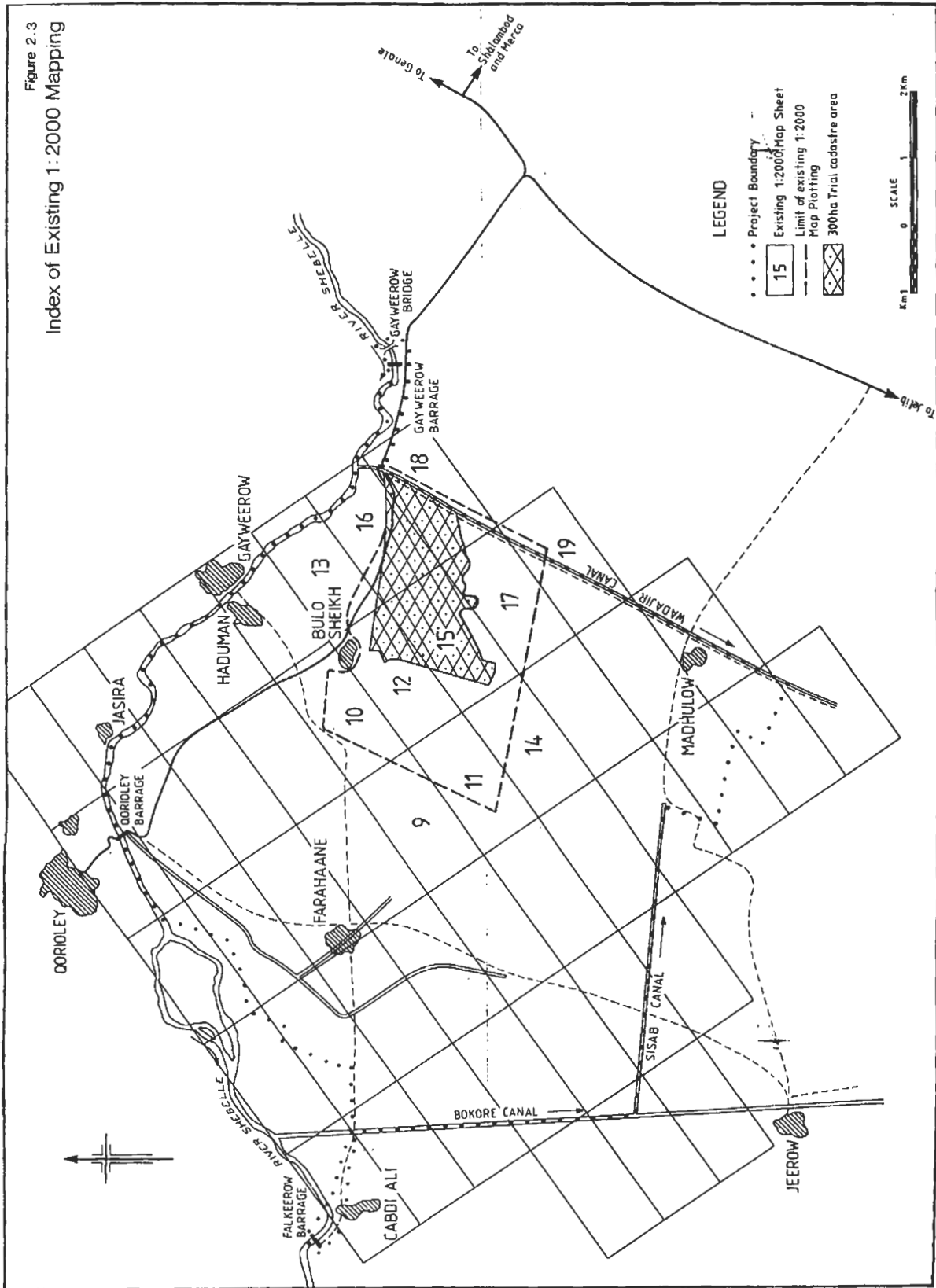

Figure 2.3
Index of Existing 1:2000 Mapping



3 TOPOGRAPHIC SURVEY FIELDWORK

3.1 Level Control

A second order levelling network was established to within an accuracy of $\pm 10 \sqrt{k}$ mm/km. This network is shown in Figure 3.1. The datum for all work is the Fundamental Bench Mark A65 on the South upstream side abutment of Qorioley Barrage thought to have been established as part of the FAO/Lockwood Studies in the 1960's and levelled to 1963 mean sea level Mogadishu. This point was also used during the MMP Genale Bulo Mereta Study in 1977, the given value of 68.199 m being obtained from that report. Identification of the mark was confidently confirmed by evidence of the remains of a white painted cross on the point. A double levelled check tie between FEM A65 and EM A39 on Gayweerow road bridge was carried out which resulted in a difference of some +240 mm when compared to the original FAO/Lockwood value given in the MMP 1977 report. Due to difficulties in identifying point A39 with absolute certainty (the pillar has been knocked over) it was decided to utilise the FAO/Lockwood value of A65 at Qorioley as the datum for all the work.

In all, 64 bench marks were levelled to a second order accuracy. They are all placed on permanent existing structures, mainly culvert head walls, and were clearly marked in the field with indelible black crosses. Identification reference sheets for 45 of these points are attached as Appendix A with this report, each having a location sketch and photographs. A list of these bench marks with their adjusted values appears as Table 3.1

In addition, level ties were made to 3 of the GeoSurvey/TAMS markers that were still found to be intact in the field and identifiable on the 1:10 000 mapping. Of these, only 2 have given values and these were some +106 mm and +73 mm greater than the values found in this work. Whilst this gives sufficient agreement as a level check on the accuracy of the contouring and spot levels on both the 1:10 000 and 1:2 000 mapping, the apparent datum difference of between +73 and +106 mm between the GeoSurvey and MMP work is cause for some concern. However without any details of the GeoSurvey/TAMS work, little can be deduced. It should also be pointed out that the 2 GeoSurvey points were only 2.1 km apart and a closing difference of 33 mm over this distance is greater than the second order level of accuracy. A possible explanation would seem to be that these were traverse points fixed for plan position and level by EDM and trigonometric heighting techniques to provide photogrametric ground control and are hence not to the same degree of accuracy as the MMP second order spirit levelled work. Such methods are perfectly satisfactory for air photo plan and height control but are generally considered insufficient for detailed hydraulic engineering surveys.

A further check was carried out by tying to the 1977 J A Story/MMP work. The new EM 27 on the bridge over the Bokore canal on the Farahaane to Falkeerow road agreed with the value on the bench mark location map of the 1977 point A60 by 7 mm. The new EM15 differed with the identical 1977 point A70 by only 4 mm. In addition the 1977 TBM's placed along the tarmac road from Bulo Sheikh to the Wadajir canal were rough checked. The 1977 TBM's being secondary points have only brief descriptions, unlike the detailed

TABLE 3.1

Primary Level Control Points

All points are to second order $10\sqrt{k}$ mm/km accuracy.

Datum Point FEM A65 Qorioley Barrage. Given value 68.199 m.
Assumed Mean Sea Level 1963 Mogadishu.

No	Value	Location	Notes
FBMA65	68.199	Qorioley Barrage	Placed by FAO 1963 Datum Point for 1987 work 1977 value was 71.182
FBMA39	71.419	Gayweerow Road Bridge	
EM1	66.665	Culvert on Tarmac Road	
EM2	66.209	Culvert on Tarmac Road	
EM3	66.329	Culvert on Tarmac Road	
EM4	66.431	Culvert on Tarmac Road	
EM5	66.803	Culvert on Tarmac Road	
EM6	66.465	Culvert on Tarmac Road	
EM7	66.171	Culvert on Tarmac Road	
EM8	66.665	Culvert on Tarmac Road	
EM9	66.783	Culvert on Tarmac Road	= MMP 1977 E17 point
EM10	66.434	Culvert on Tarmac Road	= MMP 1977 E16 point
EM11	69.151	On Head Regulator Wadajir Canal	
EM12	68.941	Culvert on Tarmac Road/ Wadajir Canal	
EM13	68.937	Culvert Wadajir Canal	= MMP 1977 E11
EM14	69.161	Road Bridge Wadajir Canal	
EM15	67.691	Road Bridge Wadajir Canal/ Madhulow	= MMP A70
EM16	66.640	Culvert on Wadajir Canal	
EM17	67.802	Culvert on Tarmac Road/ Farahaane Canal	
EM18	67.314	X Regulator Farahaane Canal	
EM19	65.543	Step of water Compound - Farahaane Village	
EM20	67.164	Culvert Farahaane Canal in Farahaane Village	
EM21	64.832	Culvert Farahaane - SISAB Road	
EM22	65.907	Road Bridge SISAB Canal	
EM23	65.845	Culvert Farahaane - Falkeerow Road	
EM24	66.113	Culvert Farahaane - Falkeerow Road	
EM25	65.234	Top of Pipe - Falkeerow Road	
EM26	64.856	Culvert Farahaane - Falkeerow Road	

Figure 3.1
 Levelling Control Diagram

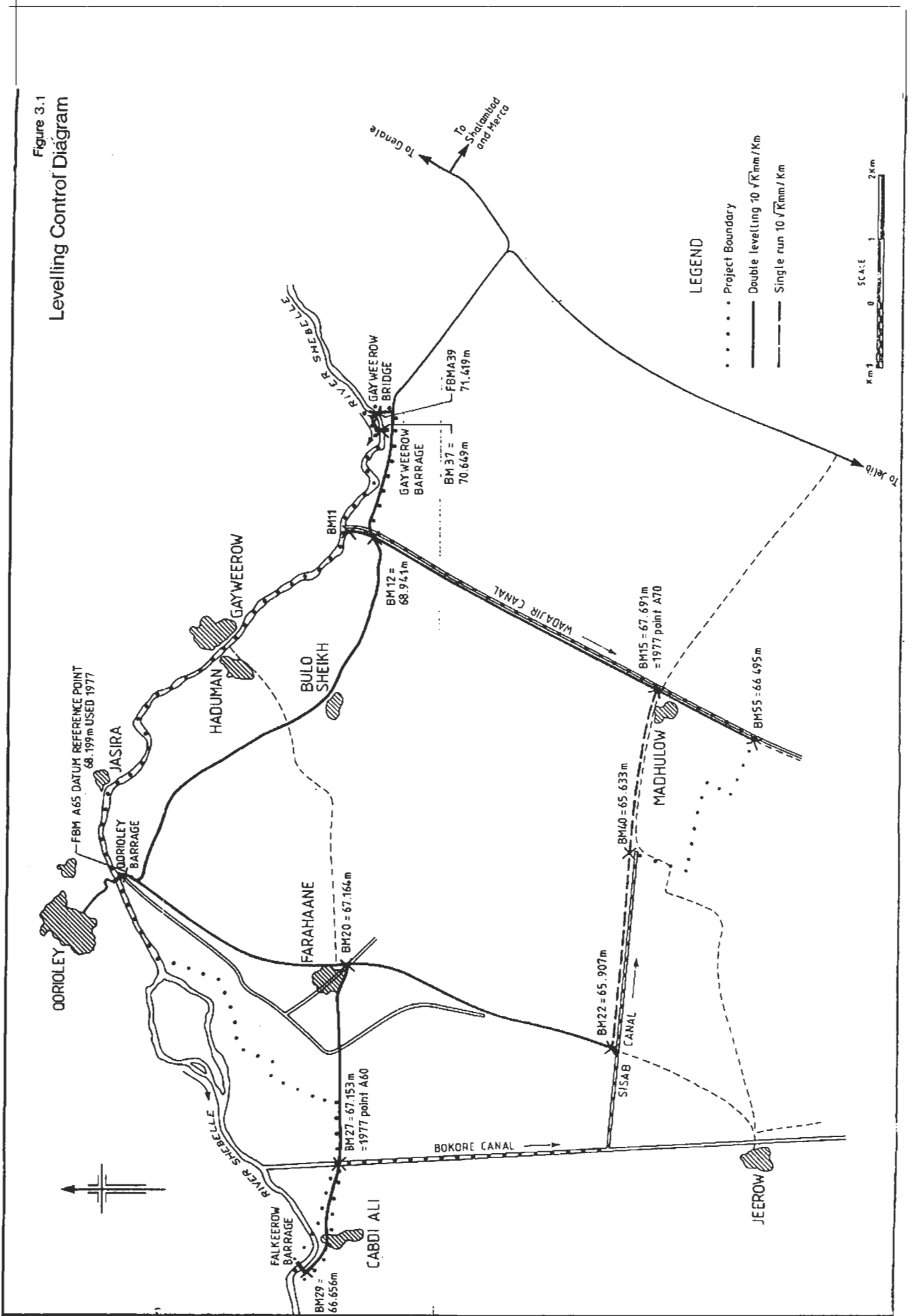

EM27	67.153	Road Bridge Bokore Canal/ Farahaane - Falkeerow Road	= MMP A60
EM28	64.832	Culvert Farahaane - Falkeerow Road	
EM29	66.656	Falkeerow Barrage	
EM30	66.713	Culvert on Tarmac Road	= MMP E15
EM31	67.337	Culvert on Tarmac Road	= MMP E14
EM32	68.595	Culvert on Tarmac road	
EM33	69.471	Culvert on Tarmac Road	
EM34	69.249	Culvert on Tarmac Road	
EM35	69.835	Culvert on Tarmac Road	
EM36	70.033	Tarmac Road Bridge over Flood Relief Channel	
EM37	70.649	Gayweerow Barrage	
EM38	71.352	Head Regulator Gayweerow Flood Relief Channel	
EM39	66.693	Bokore Canal Offtake Regulator	
EM40	65.633	Offtake at East Level of SISAB Canal	
EM41	64.976	Half Way Down Canal G3/1	
EM42	64.942	Bokore Offtake Regulator	
EM43	64.100	Half Way Down Farahaane F2 Canal	
EM44	66.167	SISAB Canal 300 m u/s BM40	
EM45	68.559	Head Regulator G3 Canal	
EM46	68.899	Settling Basin G2 Canal	
EM47	68.856	Head Regulator of Drain at G2 Canal	
EM48	68.071	Head Regulator Farahaane Canal	
EM49	65.683	Farahaane/Bulo Sheikh Road	
EM50	65.522	Step of Water Compound Haduman Village	
EM51	67.145	M H Cover Water Pipeline Haduman Ferry	
EM52	65.022	North of Madhulow	
EM53	67.005	West End of SISAB Canal, Proposed Pump Station Site	
EM54	66.371	Wadajir Canal, 40 m West of BM16	
EM55	66.495	Wadajir Canal at South End of Project Area	
TEMA	63.200	3 km South of Farahaane Village	
TEMB	64.082	1.5 km South of Farahaane Village	
TAMS	68.876	(Tams Value 68.77) Tarmac Road Edge	
TP67			
TAMS	66.463	(Tams Value 66.39) Tarmac Road Edge	
TP70			
TAMS	67.659	(No Tams Value Given) Qorioley Barrage Road Edge	
TP78			

reference sheets of the primary points (A60, A70, A65 etc) identification of the TEM's could not be made with absolute certainty. However differences of +23 mm, +57 mm, +43 mm and +57 mm were recorded for the new bench mark positions BM9, BM13, BM30 and BM31 which correspond to 1977 TEM points.

Overall good agreement was made with the 1977 MMP work and agreement with the GeoSurvey/TAMS work was within ± 100 mm.

3.2 Base Mapping

As indicated in Chapter 2 and Figure 2.2 the 1:10 000 base mapping of the project area omitted the South East and North West corners plus the barrage sites and their access roads to Falkeerow and Gayweerow. These areas were infilled using the 1:10 000 air photography as a base where it existed, namely the South East area South of Madhulow village and the North East area to Gayweerow Barrage. Spot levels were taken in the field to cover for these areas and provide coverage consistent with that already existing. The area to the North West was more problematical as it lies outside the coverage of the 1985 air photography. The 1:25 000 existing mapping produced as part of the 1977 MMP study from 1963 air photography was enlarged to 1:10 000 to give the river and road alignments. Spot levels were then taken along the road centre line and left bank flood bund upstream of Falkeerow Barrage. These were incorporated onto the 1:10 000 site base map, the site levelling tying to within 10 cm of the existing mapping.

The 1:2 000 mapping of the TAMS selected detail area was checked in the field during the cadastral survey and found to be adequate, especially when considering its source was 1:10 000 air photography and much of the infield works in the area are of a temporary nature. Levels were checked when cross sections of minor canals were carried out in the trial area.

3.3 Beacon Placement

In addition to the 64 second order bench marks, 45 pre-cast concrete monuments were placed in the field at strategic points along the proposed drain and new canal alignments. They are generally at their start, finish and joins as well as major changes in direction. They were selected using the air photography and deliberately located to run along existing farm plot boundaries as far as it was possible to identify these. The monuments were buried with some 5 cm protruding above the ground. They were placed prior to the commencement of the drain line levelling work to ensure that they were tied to each other. It was not considered worthwhile placing beacons on existing canal lines, as the locations of these are already very obvious and the bench mark levelling programme utilised existing stable points. The life expectancy of the beacons is not thought to be very long, many of the points were damaged and some destroyed during the duration of the fieldwork. Most of the beacons were levelled in the field as part of the drain and new canal long section levelling programme, however, 10 were damaged before this could be done. These points are likely to be very unstable due to the nature of the swelling clay soils and no reliance should be placed on these marks for detailed levelling work in the future. They should be considered as locational beacons only, their positions being plotted on the survey data map which will be included in the engineering drawing album. Levels of the beacons are given in Table 3.2.

TABLE 3.2
BEACON LEVELS

All levels are to the top of the upstanding rod on the top centre of the pillars.

Nr	Level	Nr	Level
100		123	65.778
101		124	64.558
102	66.643	125	65.718
103		126	63.767
104	64.320	127	64.176
105	65.689	128	
106	65.484	129	63.846
107	66.078	130	63.530
108	65.342	131	63.759
109		132	63.861
110	65.042	133	67.320
111		134	
112	64.941	135	67.107
113	64.256	136	68.665
114	64.205	137	63.775
115		138	
116	64.640	139	63.071
117	65.822	140	64.991
118	64.112	141	65.205
119	63.824	142	
120	64.265	143	63.539
121	63.967	144	64.111
122	64.088		

3.4 Cross-Sections of Existing Canals

In all, 42 km of existing canals were cross-sectioned at about 500 m intervals plus locations upstream and downstream of all structures and at any major changes in channel configuration. 98 cross-sections were levelled to within third order accuracy ($20\sqrt{k}$ mm/km) and these were scheduled and then plotted. This work was greatly hindered by the high water levels in the canals, the considerable amount of silt in the channels and also the heavy rain experienced on site during November which made access difficult. Depths of silt at the edges and centres of the channels were recorded.

3.5 Proposed Drain and New Canal Alignments

Levels of the centre lines of the proposed drain lines were taken at 100 m intervals along all 50 km of their length and closed to third order accuracy ($20\sqrt{k}$ mm/km). In addition the new canal lines were levelled in a similar manner, located like the drain lines at farm plot boundaries. These are plotted as spot levels as an overprint to the 1:10 000 project area base map to be submitted as part of the engineering drawing album.

A further 38 km of existing road alignments were also levelled in a similar manner along with 3 km of proposed new road alignment along the SISAB canal.

3.6 Additional Levelling Work

Sample cross-section levels were taken of tertiary and minor canals in the trial area as well as across the left bank river flood bund and new supply canal line. Sample road cross-sections were also taken particularly at crossing points. A site plan of the Ministry of Agriculture's compound at Gayweerow barrage was also constructed and relevant representative spot levels taken.

4 TRIAL CADASTRAL SURVEY

4.1 Introduction

The aim of the trial cadastral survey was to provide sufficient information to allow for the design of the rehabilitation of the irrigation system and provision of drainage over the 300 ha area. To this end it was necessary to identify the boundaries of every individual farm plot as a discrete unit so that the new water inlet and field drainage outlet can be located. As such, this constitutes a utility cadastre survey, however, at the same time the opportunity was taken to identify the plot owner and means of acquisition of each plot to enable the survey to be incorporated into a full legal cadastre if so required. This data also gives indications of land holding trends which could significantly affect the viability of the project and also indicate who are the likely beneficiaries of it. In addition data was collected about crop types (including trees) primarily to determine water requirements for irrigation and also to identify constraints on access/disturbance due to tree planting and perennial crops. The location of every existing water inlet to each plot was marked on the cadastral field plan and the number and (if located in the trial area) the unique identification figure of any other plots owned were recorded. A copy of the farm plot map (2 sheets at 1:2 000) is attached to this report.

The 300 ha area selected for the trial had to be restricted to that covered by the TAMS/GeoSurvey 1:20 00 mapping (see Figure 2.3). In addition it had to be a discrete unit in terms of irrigation operation ie its boundaries correspond to irrigation unit boundaries (generally canal and/or drain lines). It was also desirable to make it as representative as possible of the whole project area. For this reason the large cooperative and state farms were excluded from the area and an effort was made to restrict the proportion of land held by large farms (defined in Somalia as those with a total holding of over 12 ha) to be below that found by TAMS, ie 44% (TAMS 1987 Table 3.2.2). This restricted the location of the trial area and the area indicated in Figure 2.3 was the only one that was able to adequately cover all three major criteria, once a close study of the air photographs had been carried out and a site reconnaissance made.

The trial was also aimed as a training exercise for the counterpart member of the team attached to the survey/cadastre specialist. As such it was a great success and as a result a slightly revised farm plot card configuration was designed (see Figure 4.1). This data has been recopied onto the revised cards and a definitive separately bound set is included with the top copy of this report. A recommended methodology for carrying out the remaining cadastral survey is attached as Appendix B. This constitutes a manual for the work.

4.2 Methodology

The raw data for the survey were the unrectified, uncontrolled individually enlarged air photographs at a nominal scale of 1:2 500. These were copied in pieces on an enlarging photocopier by a factor 1.2 times to provide field copies at a nominal scale of 1:2 000. These were then rough mosaiced across photocopier distorted edges and separate photograph boundaries and fixed onto a field board. A set of sepia copies of the 1:2 000 map sheets of the

trial area were made up on a dyeline machine and these were joined together to give controlled transparency map coverage of the whole trial area. This was fitted plot by plot over the enlarged photocopied air photographs; an unsatisfactory methodology but as it was for only the limited area of the trial and due to the time constraints, there was little option but to utilise it. To overcome this it will be necessary to have controlled 1:2 000 air photo mosaics constructed and it is desirable that these are in reproducible form (screen dia-positives). A note with regard to this is attached as Appendix C. It is a major constraint to the advancement of the project and should be given urgent consideration if the project is to go ahead.

The boundaries of the individual farm plots were identified in the field by the plot occupier or somebody else prepared to speak for them. Where possible the neighbouring plot occupiers were also present to guard against any illicit land claims although there were only two disputes in the 221 plots covered only one of which concerned the location of a boundary. All disputes were easily resolved to the acceptance of all parties, by the village committee at village level without recourse to a higher authority.

The location of the farm boundaries were plotted on the enlarged photocopied air photographs by measuring in the field from points of recognisable detail with a measuring wheel and scaling off the 1:2 000 overlay. The final correct scale position was then marked on the overlay. The plot was given a unique reference number made up from a prefix the same as the map sheet numbers followed by a sequential plot number. This was written on to the overlay sheet in the centre of the plot and also inserted onto the head of the farm plot registration card. A farm plot registration card (see Figure 4.1) was completed for each plot, except in the case of the 3 farms which consisted of contiguous fields, where a card was completed for each farm with the details of individual fields being inserted on the rear of the card.

A draft version of the card was used for the trial survey but in the light of experience a slightly revised layout was agreed which emphasised the widely found situation in the project area where the farm plot occupier is also the plot owner, having either a customary right or (very rarely in this case) a statutory right to occupy the land. It was also felt that it was unnecessary to include the name of the village headman on the card as the settlement of residence of the plot owner is already given. The period over which crop types grown in the plot are to be recorded was extended to cover a full calendar year (ie 2 seasons). A tear off identity slip was also completed for each plot, containing the unique plot number; the name of the plot owner and/or occupier and their settlement of residence. These were handed to the occupiers and are required to be presented when their other farm plots are registered. This allows identification of an owners dispersed land holding and once all the land held by the inhabitants of a settlement is surveyed it is possible to obtain an accurate figure for land holding per household and per capita provided a simple household enumeration exercise is carried out.

Other data collected included the types and numbers of all fruit trees and the number of shade trees. The locations of these were plotted on the overlay with the aim of identifying areas where disturbance will need to be

SOMALI DEMOCRATIC REPUBLIC
MINISTRY OF AGRICULTURE

Farahaane Irrigation Rehabilitation Project

UTILITY CADASTRE SURVEY
FARM PLOT REGISTRATION CARD

MOSAIC No PLOT No

OFFICE USE ONLY
PLOT AREA.....ha

Full Name of Plot Owner..... Male Female (tick one)

Name of Head of Plot Owner's Household

Settlement of Residence of Plot Owner.....

If Plot Occupier is not the Plot Owner:

Full Name of Plot Occupier Male Female

Name of Head of Plot Occupier's Household.....

Settlement of Residence of Plot Occupier.....

- Type of Tenure: a) Statutory - Certificate No.....
 b) Customary (give details).....
 c) Other (state what).....

How many other plots does the owner farm (give plot numbers if already surveyed).....

List all crop types grown in the plot during the last 12 months

Improvements Fruit Trees - types and numbers.....
 Number of shade trees (Locations to be marked on map).....
 Irrigation System - number of inlets and nearest canal location (Canals and direction of irrigation in field to be marked on map).....

Enumerator/Surveyor's Name.....Date of Survey.....

IDENTITY CARD - (to be given to plot owner and produced when owners other plots are surveyed)

Mosaic/Map NoPlot No.....

Full Name of Plot Owner.....

Settlement of Residence of Plot Owner.....

If Occupier is not the Owner : Full Name of Plot Occupier.....
 Settlement of Residence of Plot Occupier.....

minimised. The crops grown in each plot over the last 12 months (2 seasons) were recorded in order to provide data for water demand, although it should be pointed out that water availability was said to be a major constraint upon crop choice at present (along with labour availability) and it seems likely that if a year round dependable supply of water was made available to each plot then higher value, more water demanding crops, would be grown in the future. The location of all irrigation channels along with their direction of flow was recorded on the overlay as well as the direction of flow within the basins of each plot. The card was completed by giving the enumerator/surveyors names and the date of survey.

The areas of each plot were accurately measured in the office using a planimeter on the farm plot overlay sheet. These were measured to an accuracy of ± 0.01 ha and entered on the farm plot registration cards once they had been scheduled and calculated on the appropriate sheets (Figure B1).

4.3 Farmer Relations and Participation

Very close liaison was made with the village committee at the nearby village of Bulo Sheikh, the inhabitants of which were the major land occupiers within the trial area. Day to day contact was maintained with the village head, who despite his already considerable duties gave up a significant amount of his time to help the survey team, particularly in tracing plot occupiers who could not easily be contacted and also in resolving any disputes. Other members of the village committee also assisted where their very sound, detailed knowledge of land holding patterns proved invaluable.

Two large village meetings were held in Bulo Sheikh, the first before the fieldwork started to explain why the work was being carried out and what it entailed. Despite this there was a reluctance on the part of many occupiers (particularly women who are significant land owners) to come into the field when asked to show their plot boundaries. It took over 4 weeks to overcome this reticence, brought about it is thought by distrust over government intentions in the area following some bad experiences on a nearby project. A very well attended second meeting was held in the late afternoon of the last day of fieldwork during which a very positive response was forthcoming. The one outstanding registration was completed and everybody present seemed happy that every plot within the trial area had been registered to the satisfaction of all parties. A one hundred percent record over such an area was considered a very good achievement.

At open question times during the meetings, very pertinent issues were raised, particularly with regard to the operational programme of contractors outside the dry season. (Note that the farmers consider February, March and April the dry season when there are few standing crops). The possible destruction of trees and perennial crops particularly along the new supply canal lines was raised as was the maintenance of water in canals during construction time. These points are dealt with more fully in Section 4.5. It did however demonstrate that the local farmers are well organised and have strong perceptions of the problems caused by the disruption that can occur during the construction of this type of project. It seems likely that the residents of Bulo Sheikh now see farm plot registration as being in their own interest. However, very careful programmes of enlightenment will

need to be carried out in other villages in the project area. Particular issues that had to be overcome were the fear that registration was at worst the first stage in a programme of expropriation of land by the government and at best a more accurate method of assessing land taxation. Only careful liaison with the affected people well before implementation can overcome these fears.

4.4 Findings of the Cadastral Survey

The trial area comprised 323.85 ha gross of which 312.26 ha (96%) was claimed and registered as part of the survey. The remaining 11.59 ha were roads, tracks, canals and scrub land at the sides of roads. Within the claimed area there were three private farms covering 37% of the total. These are very different in structure to the other 217 plots which are truly smallholder in nature.

These three farms each comprise contiguous fields to form a total land holding, the smallest of which covers 10.11 ha (technically still a small farm within the context of Somalia where 12 ha is considered the maximum size for a small farm). The other two are large private farms, the one covering 87.09 ha and totally within the trial area being statutory registered. It had been hoped to minimise such farms within the trial area, however, a large part of this farm took on the appearance of smallholder land on the air photography as it was at the time rented out in small parcels. The landowner made it known to the survey team that it is his intention to cease renting out the land from next season as a result of a promised bank loan which will allow him to implement his plan to farm the area on a large scale mechanised commercial basis. It was thus decided to register the farm as a single holding in the name of the owner with a unique number for the whole farm with alphabetical suffixes for each field, the details of the proposed crop types being noted. Further enquiries were made on a sample seven rented plots in the farm to ascertain land holding trends within the area and to assess what impact the project is likely to have there. It transpires that the majority of the people renting land are landless people who originally come from the Baidoa area (generally young, single, or recently married men) who are attempting to move into irrigated agriculture, as they see it to be less risky and more profitable than the single season dry land farming that they were previously doing. Most live on the nearby banana estate village where they work as wage paid landowners. They farm their rented plots for subsistence food production paying the first seasons rent (approximately 2 000/- per hectare per season) in advance from their savings gained from rain fed farming at Baidoa and subsequently from their wage paid labour (between 250/- and 600/- per day depending upon seasonal demand) on the banana estates. There can be little doubt that their loss of access to rentable land will be a serious problem, depriving them of the means to produce their subsistence food crops. This looks likely to happen irrespective of the future development of the project as larger farmers are more easily able to secure access to commercial credit using land (particularly statutory registered land) as collateral for a loan. If successful, the development of the rehabilitation project will probably increase land values and hence cause rents to rise. The guaranteed supply of all year water could well make added reason for larger farmers to cease renting out their land and to take advantage of the higher yields and

high value cash crops that could be grown by doing this themselves on a large scale.

The other large farm on the South West corner of the trial area had only 18.49 ha of its land within the trial area boundary, the remaining 30 ha being outside. This farm is owned by an absentee landlord and run on his behalf by a wage paid manager who lives on the site and is given some land for his own subsistence food crops. The farm is not effectively run and comparatively poor use is being made of the existing land and water resources, especially when compared to the intensity of operations on the smallholders' plots. The biggest constraint to development was cited as a lack of labour particularly for planting, weeding and harvesting along with a lack of water for all year irrigation. Overall it seemed that the farm was being held for its land asset value and the quantity of crops produced was a secondary consideration. As such it would seem difficult to see how the rehabilitation project could be made effective without a major change in management priorities and an investment in machinery to overcome the lack of labour.

This situation contrasts greatly to that on the 10.11 ha farm which was very intensively farmed using machinery, the owner managing the farm directly and growing commercial cash crops over the whole area. The crops are varied from season to season but the whole area was under the same crop at any one time. At the time of survey he was about to plant tomatoes for sale (at a pre-planting guaranteed fixed price) to the canning factory at Afgoi. There can be little doubt that this farm would benefit greatly from the rehabilitation project allowing more intensive irrigated crops to be grown over a larger period and probably with less risk as a result of better water availability.

As an indicator of the types of larger farm, the three multiple plot farms studied were valuable being as they are managed in such different ways. How representative they are of the whole project area is very difficult to determine. According to the map (see Figure 4.2) in the University of Wisconsin report some 29% of the project area is under large statutory registered farms. This compares with 44% (admittedly the area boundaries are a little different) in the TAMS study area being large (ie over 10 ha) farms and the 37% obtained in the trial area of this study. It seems to be the case that the large farms to the South edge of the project area are less intensively farmed, a significant factor probably being a lack of water in the dry season (they are at the tail end of the water delivery system) combined with local rainfall, flooding and surface salinity during the wet season. The large farms south of Qorioley barrage, and particularly those South of the tarmac road, appear to be more intensively farmed although nothing like that of the smallholder plots.

Before discussing the findings of the survey for the smallholder area it is worth noting some background information on the trial area. Much of the trial area land is held by people living in the highly nucleated settlement of Bulo Sheikh. It seems likely that the original village of Bulo Sheikh was founded between 1860 and 1890 by religious Sheiks and freed riverine people who had previously worked as slaves on arab owned irrigated farms, (see Boston University Report for US Aid 1985 page 17). Whilst this type of settlement (known as fariqas) is not unique in the project area (the village

of Farahaane seems to be similar) it is very different in structure to the agro-pastoral settlements, of which Qorioley is a large example. The banana estate villages are very different yet again from either of these. Bulo Sheikh is characterised by a very well organised traditional social structure having practised self managed small scale irrigated agriculture for a considerable period of time. Nearly all the descendants of the original inhabitants have long established rights to land although there is considerable variation in the size of land holdings and number of plots per household. There appears to be strong social pressures in the village to utilise land resources as fully as possible and also a strong tradition of welfare provision for the less fortunate in the village, particularly with regard to the loaning of land to those in need. About 10 years ago a programme of village centralisation was carried out and some of the smaller surrounding settlements were moved and amalgamated with Bulo Sheikh. This seems to have been carried out without a great a degree of antagonism and some land reallocation using the land formerly occupied by the small settlements as compensation for that taken for the extended village housing areas was carried out.

It would thus seem that the land holding situation at Bulo Sheikh is only typical of part of the total project area. The smallholders land covers 63% of the net trial area and comprised 218 plots with an average size of 0.90 ha. The distribution of plot sizes is however very uneven with a range between 0.10 ha up to 6.12 ha but 61% of the plots are smaller than the mean size of 0.90 ha. Table 4.1 shows the distribution of plot sizes in 0.5 ha units with a breakdown to 0.10 ha units for the plots under 0.99 ha. The smallest plots (ie those below 0.29 ha) are generally owned by divorced or elderly women living on their own.

It is impossible at this stage to give exact figures for land holding for each household as only a small part of the village's land has been registered. Similarly without a household enumeration it is impossible to give a figure for land per capita. However, by using an average plot size figure of 0.90 ha and the responses to the question regarding how many other plots each occupier has, an average figure of 1.89 plots per household totalling a mean size of 1.7 ha total land holding per household is arrived at. The 218 smallholder plots covered in the survey were owned by 145 households some of who had a total of 56 other plots outside the trial area.

Figure 4.2
Registered Large Farms

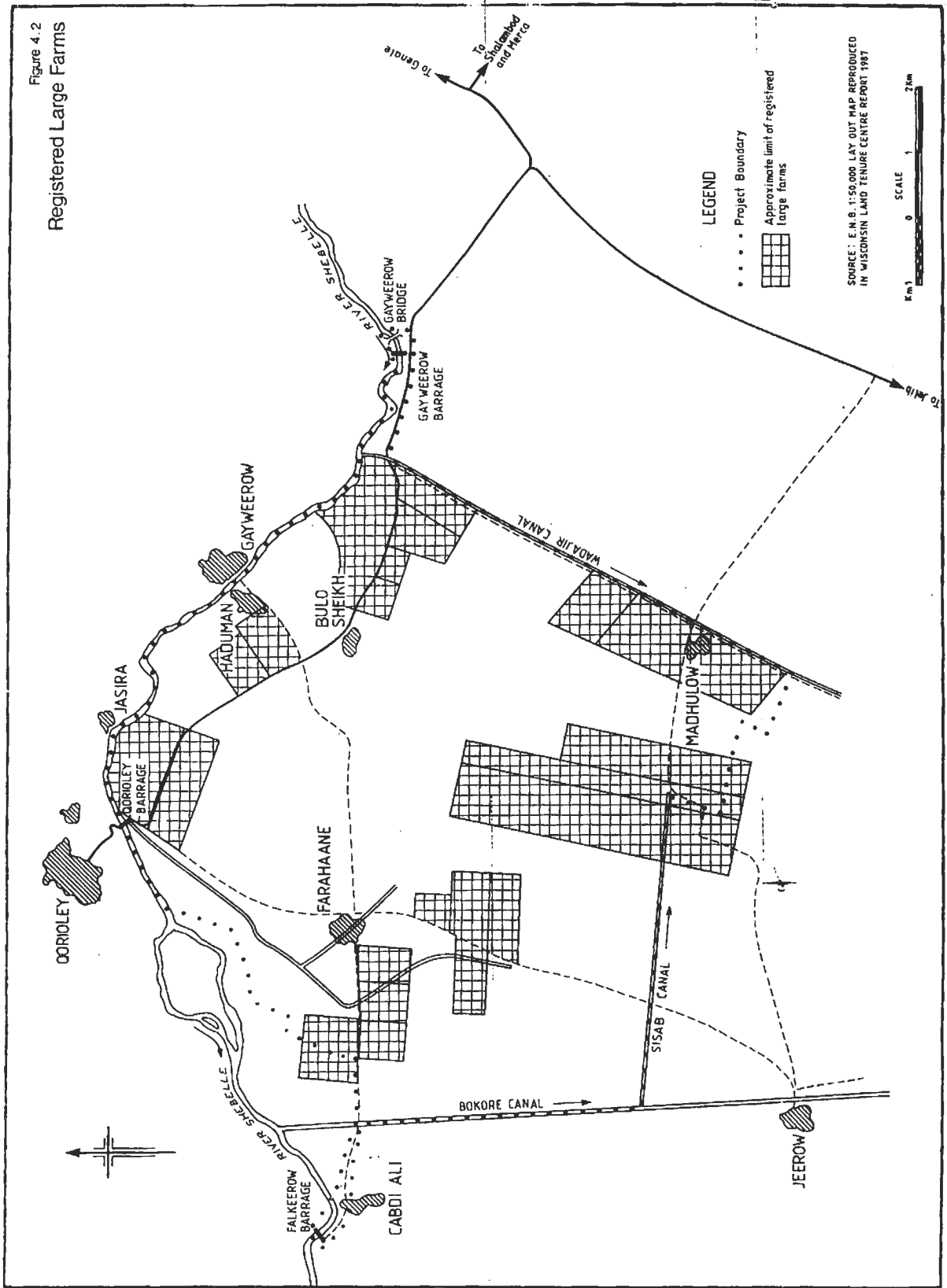

TABLE 4.1
SIZE OF DISTRIBUTION OF SMALLHOLDER FARM PLOTS
IN TRIAL AREA

Plot Size (ha net)	Number of Plots	
0 - 0.09	0)	
0.1 - 0.19	5)	
0.2 - 0.29	19)	88
0.3 - 0.39	35)	
0.4 - 0.49	29)	
0.5 - 0.59	17)	
0.6 - 0.69	13)	
0.7 - 0.79	9)	62
0.8 - 0.89	14)	
0.9 - 0.99	9)	
1.0 - 1.49		33
1.5 - 1.99		15
2.0 - 2.49	6	
2.5 - 2.99	6	
3.0 - 3.49	6	
3.5 - 3.99	0	
4.0 - 4.49	1	
4.5 - 4.99	0	
5.0 - 5.49	0	
5.5 - 5.99	0	
6.0 - 6.49	1	

	218 plots	

Note: Trial area = 312.26 ha net
(323.85 ha gross)

The distribution of the number of plots is shown in Table 4.2, the majority of householders owning only one plot, but many of these (particularly those with more than 2 people) rent other land from within the village mainly from those plot owners who have more than two plots and have insufficient labour to farm it.

TABLE 4.2
THE NUMBER OF PLOTS HELD BY EACH HOUSEHOLD
IN TRIAL AREA

Number of Plots Held	Number of Households
1	65
2	50
3	16
4	11
5	1
6	2

TOTAL	145

Total number of plots held by the 145 households is 274, of which 218 are in the trial area.

Each household has a mean 1.89 number of plots of mean size 0.90 ha.

The trends with regard to land holding are complex, especially when such detailed and complete data is studied. It appears that the buying and selling of land is now very rare indeed (only one plot has been sold within the trial area in the last 5 years) it being recognised as the major asset in the village. This is quite unlikely to be the case in agro-pastoral villages where livestock is probably regarded as the most important asset. There has been no unclaimed or unallocated 'spare' land in the area for many years and due to increasing demand land values have risen sharply in the last 20 years. The last piece of land sold in the village was two years ago and went for a price of 22 000/- per ha. Enquiries revealed that, if available, land would sell for at least twice this figure and in the Genale area where irrigation water is obtainable throughout the year, prices of 100 000/- per ha are common. There have been spates of land changing hands in 1962, 1972 and 1979 probably coinciding with periods of economic difficulty in the village, as debt was given as the main reason for people being forced to sell land. The purchase of land by people from outside the village is extremely rare, nearly all land being bought and sold within the village. There was one case recorded of a pastoralist from the clan at Qorioley (not a refugee from the resettlement area) selling up his livestock and buying a significant sized farm plot to start sedentary agriculture. This case seems extremely rare and due to present land shortages it is difficult to see how this could happen today. However, it should be pointed out that although land prices are relatively high, livestock prices are higher still (cattle were priced at 30 000/- per head and camels 50 000/- at the time of survey) and the sale of only two camels would realise enough capital to purchase one hectare of land. One or two cases of dry land farmers from the Baidoa area buying land some 10 or 15 years ago were recorded but it took them about five years to amass sufficient capital (by

working as wage paid labour on the banana estates) to do this and it would seem inconceivable that this could be accomplished today with land availability being so scarce and social pressure to keep land ownership within the village being so great. There seems to be an increasing trend to rent out land for cash on a season by season basis rather than sell it.

The ownership of smallholder land is thus concentrated in the hands of local villagers and the sale of land is becoming increasingly rare. It would seem likely that this will remain the case in the future. As regards landowners means of acquisition, by far the most common method was inheritance from a father, husband or mother and less commonly sister, brother, aunt or uncle. It is interesting to note that women are significant landowners, inheriting land from their husbands (most men marry younger wives who outlive them) at death as well as from divorce settlements and mehar (a kind of dowry paid at the end of a marriage rather than before it). Landownership in time appears to be amassing amongst women who also receive exactly equal shares as men during the subdivision of land at the death of their parents. It is also common to find widowed women being considered heads of large households. Other methods of land acquisition included plots held by old men who were heads of large households and were allocated land from the Italian colonial authorities, however within a few years these plots will be inherited by their children and instances of this will go unrecorded. Short term loaning of land without payment seems particularly common practice when people were temporarily living away from the village, as was the case with three women working in Saudi Arabia. Cases of land being given as gifts to single young men by their fathers were quite common, generally as a first step to their setting up independent households whilst their fathers were still alive. One case of a plot being held in trust by an uncle for a family of 5 young orphaned children was recorded, the age of majority at which individuals can own land being 14 years. One example of share cropping was found but this seems to be rare, renting land for cash being far more widespread. Rents were generally about 3 000/- per hectare per year although figures of over twice this rate were recorded in some instances.

The staple subsistence crops recorded in the plots were maize, sesame and beans with a wide range of cash crops also being grown including tobacco, tomatoes, sweet potatoes, sugar cane, groundnuts, chillis, green peppers and the marrow/melon/pumpkin family. Most of the cash crops were for sale in local markets, although there is great potential for cotton providing the necessary infrastructure can be provided to transport it to the ginnery at Balcad and a worthwhile guaranteed fixed price can be given before it is planted.

Tree crops included bananas/plantains for self consumption, mangos, annoi (annona muncata or soursop), papaya, guavas, date palms, limes and coconut palms. There were also a considerable number of shade trees (especially casuarinas) recorded, many of which have been planted on plot boundaries in the last 5 years.

Major constraints to agricultural development in the area were identified by the farmers as a lack of labour, particularly for planting and weeding, coupled with an inadequate provision of tractor hire services (these are mainly private at present) particularly at peak times for land preparation

prior to planting. Some plots had not been planted with a second seasons crop for this reason. A lack of credit facilities to pay for the costs associated with tractor hire (as well as insecticide and fertilizer) incurred prior to any income being received from crop sales, were also given as major constraints. In many cases these were seen by farmers to be greater problems than those of water shortage, lack of drainage and siltation of the canals which the rehabilitation project is aimed at tackling.

In addition to the cadastral survey, enquiries were made regarding water users associations, the existing procedure for statutory registration of land and details of compensation procedures and rates for the development of land and disruption caused by construction works. The results of these enquiries are dealt with in the following Section 4.5, which addresses itself to the impacts of the project and suggests ways of ameliorating these effects.

4.5 Potential Impacts of the Project

The short term impacts of the project are likely to be of a disruptive nature encountered during the construction of the project. It is necessary that very careful consideration is taken of these and efforts are made to minimise and overcome them as they could well affect the short term viability of the project and prevent the longer term benefits of the project from being realised (see Bird A C 1984 for examples of these from projects actually built in Africa).

There will be permanent land loss under new irrigation works, particularly those areas which will lie under new drain and canal alignments and the settling basins. This land loss needs to be minimised and spread in as egalitarian a manner as possible, probably by locating such alignments on any unclaimed land and along plot boundaries. Compensation for land taken is generally on a replacement basis, either alternative equivalent land being given to that lost (as was the case with the previous village centralisation programme carried out in the project area) or a cash payment being made. Due to the unavailability of equivalent replacement land in the area there is little alternative but to pay cash compensation. This should be based upon a per hectare rate which reflects local land values, so that in theory alternative equivalent land could be purchased. A figure of between 40 000/- and 60 000/- per hectare would seem realistic at 1987 prices. This land must be expropriated in the legally recognised manner well before any construction work is due to start. This will require the completion of the survey over the whole project area and the production of land expropriation plans along with the pegging out of expropriation limits in the field.

There is likely to be temporary disruption to the farming operations in the project area as the contractor will require access to parts of the project area at various times. There will undoubtedly be conflicting demands between the requirements of the contractor to work in an efficient economic manner and the need to maintain farming operations in the project area. It should be noted that the period between February and April is the time when there are fewest standing crops in the area and contractor's operations should be concentrated in these times. These potential conflicts can only be resolved by careful programming of the contractor's work and close

liaison with the affected farmers will be necessary. This is particularly the case where access is required to an area where standing crops would normally be in place. The destruction of any annually grown standing crops should be avoided at all costs and this is best done by placing planting restrictions on areas where access is required. These will need to be pegged in the field in advance of normal planting time and disturbance compensation equivalent to the value of the crops unable to be grown must be paid, preferably in advance of the contractor moving in. It may also be necessary to provide food aid in extreme cases and the possibility of employing temporary wage paid labour from within the project area to mitigate against these cases should be investigated. This would seem particularly appropriate for canal remodelling in areas where high value tree crops are grown as the canal banks and machine operations are not possible without the destruction of the tree crops.

The destruction of trees and perennial crops (particularly along the new canal lines) will undoubtedly have to take place although this can be minimised by careful planning and selection of appropriate alignments. The scheduling, pegging and payment of compensation for these should be made well before any construction machinery enters the area. Compensation rates paid on the Genale Bulo Mererta project are shown in Table 4.3, although it should be pointed out that these are very low when compared to internationally recognised techniques for their calculation. For example a typical mature mango tree in the project area will produce around 3 200 large fruit a year with a quoted price of 7/- each in the market; this realises 22 400/- per year. Over the recognised five year period for which compensation is usually paid, this would total 112 000/- compared to the listed rate of between 2 000/- and 5 000/- per tree being paid on the Bulo Mererta Project.

TABLE 4.3

LIST OF COMPENSATION RATES PAID TO FARMERS FOR THE DESTRUCTION OF TREES ON THE GENALE BULO MARENITA IRRIGATION PROJECT

Type	Size	Rate in Somali Shillings
Mango	Large	2 000 - 5 000
	Small	200 - 1 000
Coconut	Large	1 000 - 3 000
	Small	100 - 1 000
Lime	Large	500 - 1 000
	Small	100 - 500
Anoni		200 - 300
Casuarina (shade tree)		300

The construction of the Gayweerow Primary canal will also necessitate the destruction of an existing residential compound close to the river by the Gayweerow-Haduman river ferry crossing. Using recognised calculation techniques the cost of replacing the two buildings (an 8 m x 4 m hut and a 5 m diameter Muduh) will be 86 000/- and 27 000/- respectively. This has been calculated using the market rates for traditional building materials at Qorioley market and labour estimates from local house builders. This does not include compensation for the land on which they stand as it would seem realistic to give equivalent alternative land next to the village.

The remodelling of the existing canals in the project area will require small, probably labour intensive, techniques in some areas if the destruction of valuable tree crops is to be avoided. This would also help the local economy by providing seasonal wage paid employment although the existing stated labour shortage in the area could mean it is difficult or expensive to recruit.

In the medium and longer term the benefits of the project should start to outweigh the initial losses. However, the local farmers, particularly the small ones who own little land, need to be cushioned from these initial detrimental impacts if they are to be in a position to take up the longer term benefits of the project.

To promote the aim of self management of the project using the existing water users groups (Yeersins) it will be necessary to assist the members of the committee with advice regarding the revisions to the water scheduling system required as a result of changing the capacities of canals and the areas which they serve. The present system relies upon the experience of the individual water officers allocated to each of the secondary canals. They are paid 100/- per irrigation by the plot occupiers and are charged with scheduling irrigations and the physical opening of canal banks, fines being imposed for unauthorised opening of canal banks. In addition the committee is responsible for canal maintenance and again a training programme would be required to assist them in revising their methods to be appropriate to the post rehabilitation situation.

Consultations were held with the officer at the Ministry of Agriculture in Qorioley responsible for land registrations matters. From these it appears that the present system of land registration is very unwieldy and time consuming with 18 months seeming to be the typical length of time for a registration to be fully completed. It requires that the plot occupier has to have sufficient time and commitment to follow up their application. The costs involved are also beyond the means of many of the smallholders, which when added to the farmers perceived lack of benefit to them from land registration, results in few of them having statutory registered plots. Additionally, the methodology being utilised is restricted as there is no master plan upon which all registered land is plotted. As far as can be seen there is no reason why the trial utility cadastre survey data cannot be used to allow statutory registration to take place in the normal manner. The requirement for authentication by a Somali licensed surveyor may need to be considered but the farm plot boundary map and registration cards will provide the information necessary for the Ministry of Agriculture to make up the documentation required under the present system.

The granting of statutory rights of occupancy should be seen as a desirable procedure for the project so that changes in land holding patterns can be observed and if required, land transactions can be controlled. This is particularly useful in protecting smallholders from the possibility of wealthy outsiders acquiring land in the project area, which in the light of the discovered inefficiencies of some of the larger farms, should be considered as undesirable. The resources of the Ministry of Agriculture Office in Qorioley will need to be strengthened if the project is to go ahead, as it seems sensible for this office, or perhaps a project sub-office to deal with all land and compensation matters.

Other pertinent environmental impacts of the project include health considerations, access, livestock and firewood. Of these, health considerations are the most serious. Judging by past experiences in irrigation areas in Africa, the provision of all year water and particularly drains containing standing water will result in increasing instances of water borne diseases, particularly malaria and bilharzia. This will eventually prove detrimental to human activity rates and hence agricultural output in the project area. A health education programme along with the provision of safe drinking water supplies and adequate latrine facilities is the most appropriate way of dealing with this. It should be pointed out that some of the project area settlements have just been provided with piped water supplies but, due to the salinity of the water and the fact that a small charge is made for it, the people are still extracting water from the irrigation canals. This is a disturbing trend and is likely to become more widespread if canal water levels are maintained all year round.

In the last 15 years there has been a considerable increase in the number of livestock which pass through the project area. This is primarily due to the setting up of the refugee camps near Qorioley. Provision needs to be made for the improved roads to have a wide verge at one side to allow the passage of livestock. The provision of livestock watering points should be considered to reduce the incidence of canal banks being damaged by being used for animal watering.

Tractor and pedestrian access to all parts of the project area needs to be maintained, the location of crossings over new canals and drains being a crucial factor here. Close liaison with the local population as to the best sites for these is likely to result in the most appropriate locations being chosen and the potential access problem being minimised.

If the project is successful it is likely that the agricultural operations in the area will be intensified. The remaining areas of bushland in the southern end of the project are likely to be cleared and this will create yet more pressure on the demand for firewood. This is likely to result in even more pressure on the marginal areas towards the sand dunes with possible severe ecological consequences. Consideration should thus be given to promoting fuel wood lots nearby to try and ameliorate these effects. Early incorporation of this into project planning is required if the problem is to be adequately tackled.

4.6- Conclusions

If the project is to go ahead then a careful programme of liaison with the local farmers will be required as they are at present reticent and suspicious of government intentions in the area. Difficulties have already been experienced in other projects nearby and the commitment of the local population to the project is not going to be easily gained. It would perhaps be a good idea to initially develop a small trial area with a phased programme over the rest of the project area if the trial is successful.

A cadastre survey will be needed for the remaining part of the project area and will be necessary before details of the minor canals and drains can be finalised. In order to carry out the survey it is necessary for controlled air photo mosaics to be constructed (see Appendix C). The methodology for the cadastre survey is outlined in Appendix B and the logistical requirements for this survey given in Appendix D.

Realistic compensation rates are required for land taken under the permanent works and for trees destroyed as well as for the disturbance caused due to the contractor requiring access to the site which will prevent people planting crops. Previous experience with this type of work has demonstrated that it is very difficult to reconcile the requirements of an international capital intensive construction contractor to operate in a cost effective manner with those of the existing small scale highly intensive agricultural operations at the same time as each other. The drawing up of a realistic phased works programme designed at minimising disruption to existing farming that is acceptable to all parties is a pre-requisite for the project to be successful.

There will also be environmental impacts that will affect the success of the project and it is necessary to incorporate measures to reduce these at an early stage of the planning of the project.

APPENDIX A
BENCH MARK REFERENCE SHEETS

FUNDAMENTAL BM A65

ELEVATION 68.199

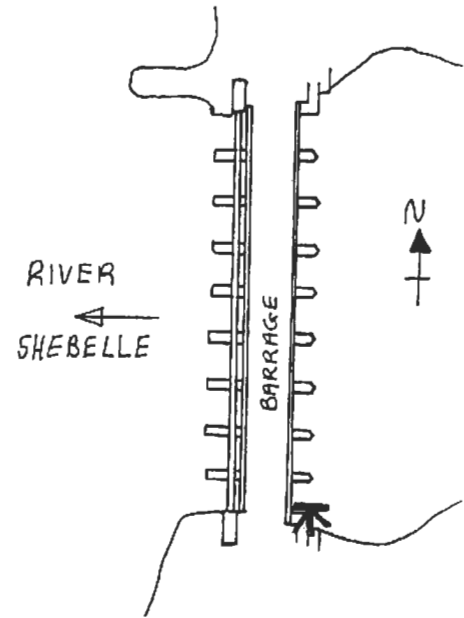
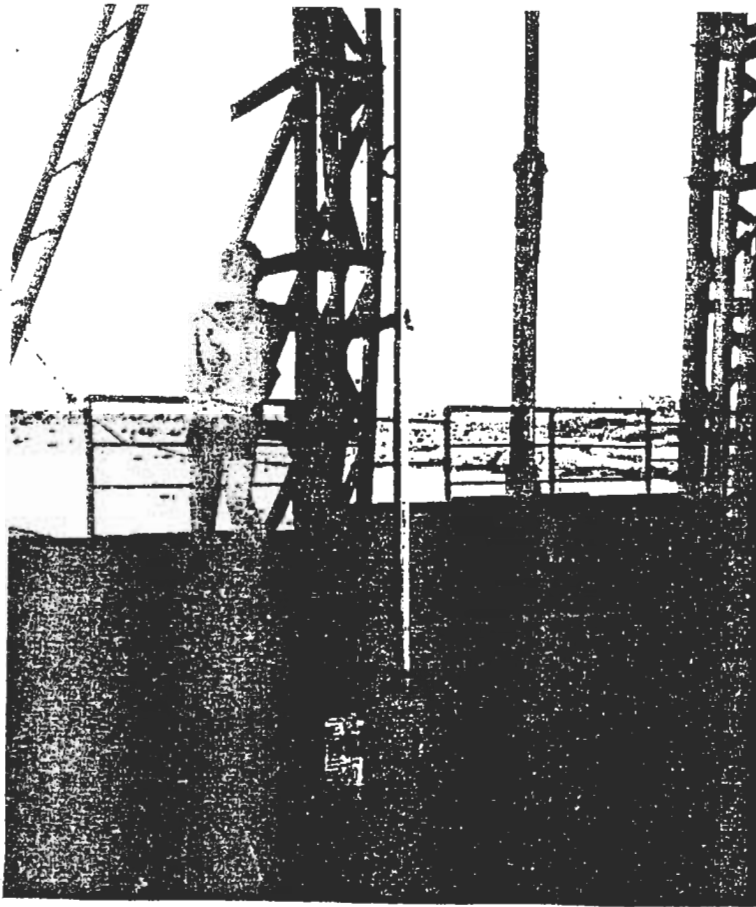

DESCRIPTION

Qorioley Barrage

FBM A65 is on the north east corner of the upstream left bank concrete abutment.

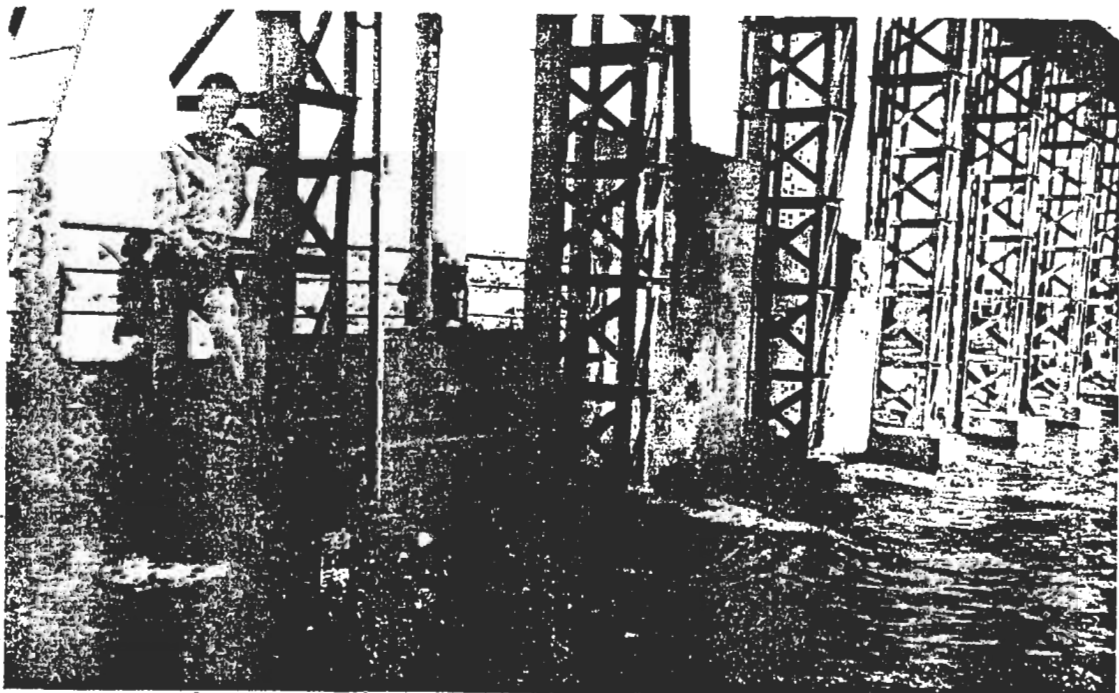

FUNDAMENTAL BM A39

ELEVATION 71.419

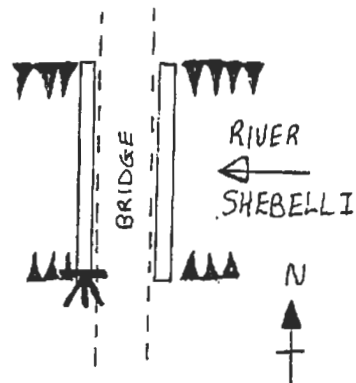

DESCRIPTION

Gayweerow Road Bridge

FBM A39 is on the concrete base at the south west end of the bridge. The base was for a pillar which has been knocked over.

BM 1

ELEVATION 66.665

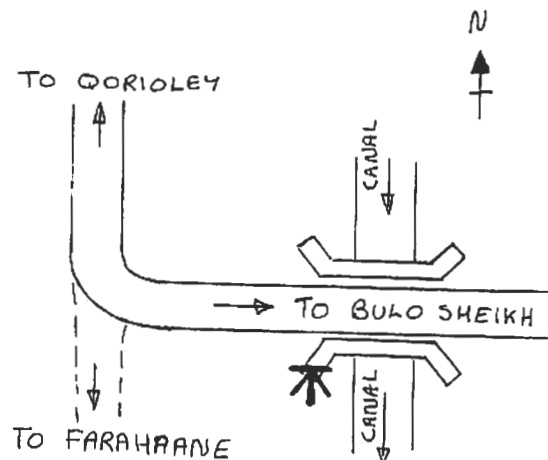
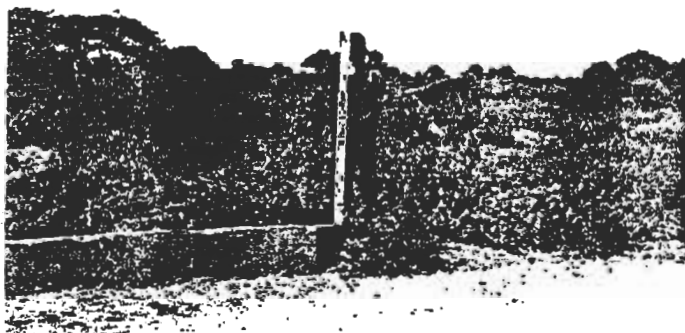

DESCRIPTION

BM 1 is on the centreline of the downstream culvert head-wall at the western end.

FARAHAANE IRRIGATION REHABILITATION PROJECT
 REGISTER OF PERMANENT BENCHMARKS
 DATUM: 1963 Mean Sea Level, Mogadishu
 DATE OF LEVELLING: November 1987

FIGURE A.3

BM 2



ELEVATION 66.209

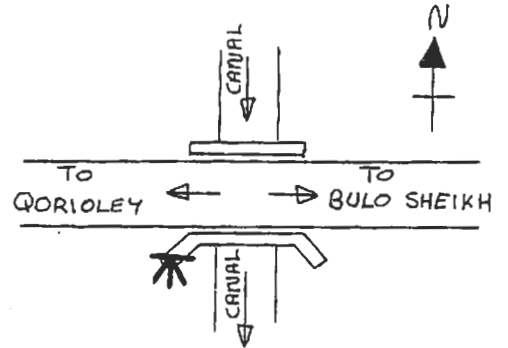

DESCRIPTION

BM 2 is on the centreline of the downstream culvert headwall at the western end.

BM 3

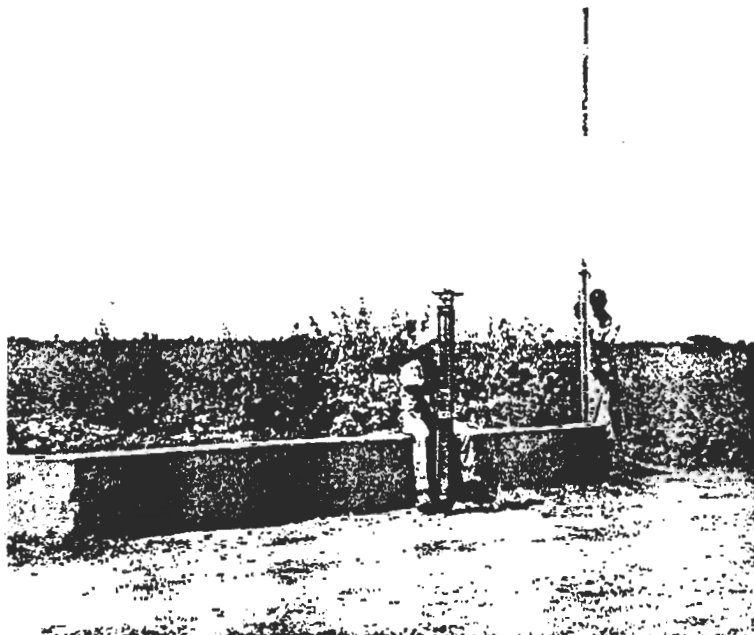

ELEVATION 66.329

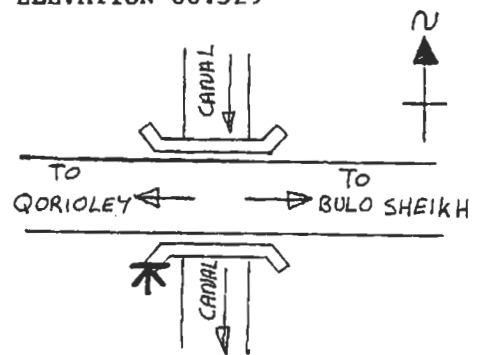

DESCRIPTION

BM 3 is on the centreline of the downstream culvert headwall at the western end.

BM 4

ELEVATION 66.431

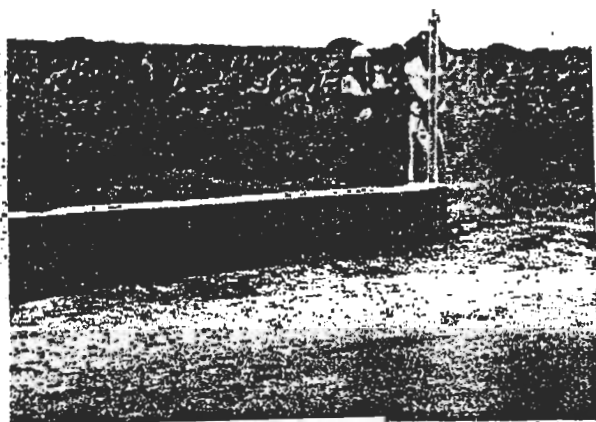
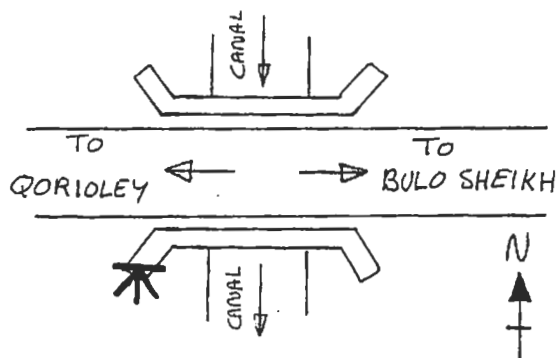

DESCRIPTION

BM 4 is on the centreline of the downstream culvert headwall at the western end.

BM 5

ELEVATION 66.803

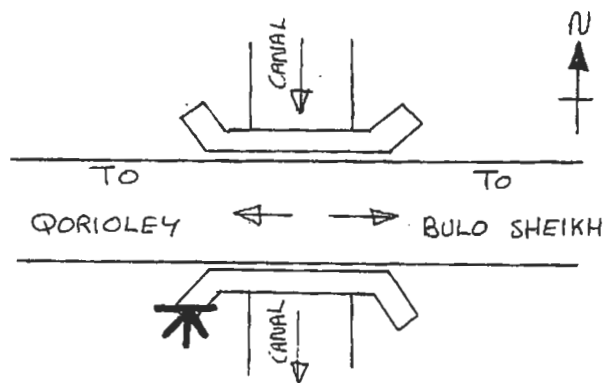

DESCRIPTION

BM 5 is on the centreline of the downstream culvert headwall at the western end.

BM 6

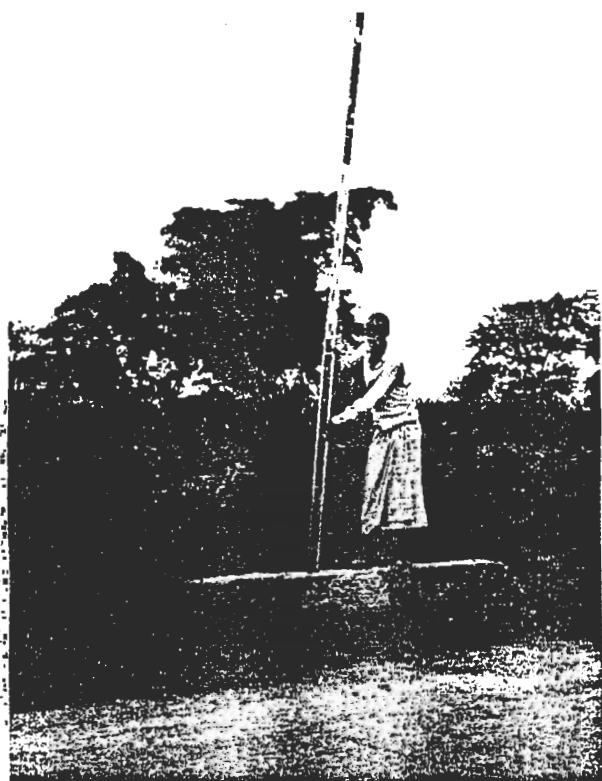

ELEVATION 66.465

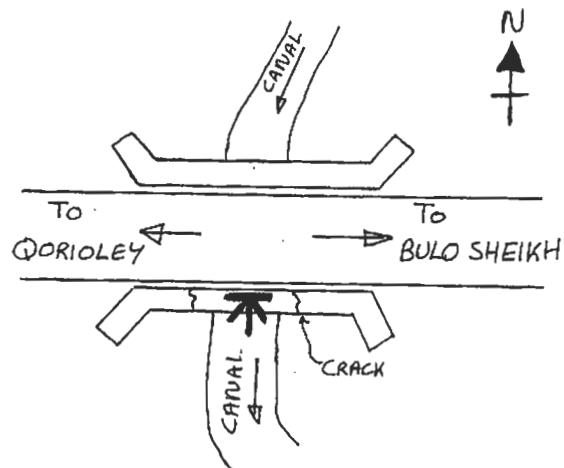

DESCRIPTION

BM 6 is on the centreline of the downstream culvert headwall at the centre between the two large cracks.

BM 7

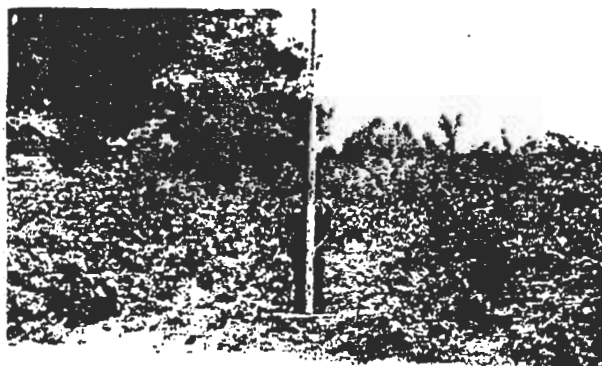

ELEVATION 66.171

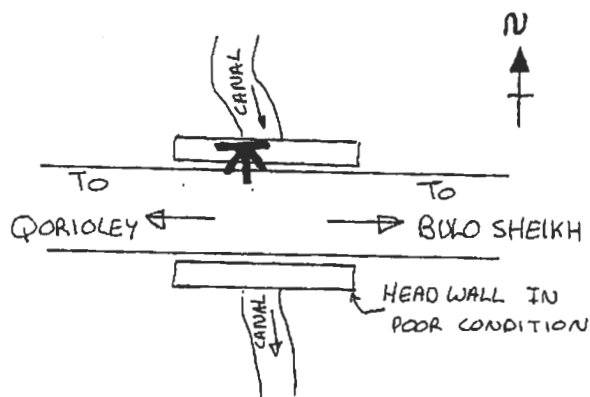

DESCRIPTION

BM 7 is on the upstream culvert headwall on the only piece of flat topped stable concrete, approximately in line with the west edge of the canal.



FARAHAAANE IRRIGATION REHABILITATION PROJECT
REGISTER OF PERMANENT BENCHMARKS
DATUM: 1963 Mean Sea Level, Mogadishu
DATE OF LEVELLING: November 1987

FIGURE A.6

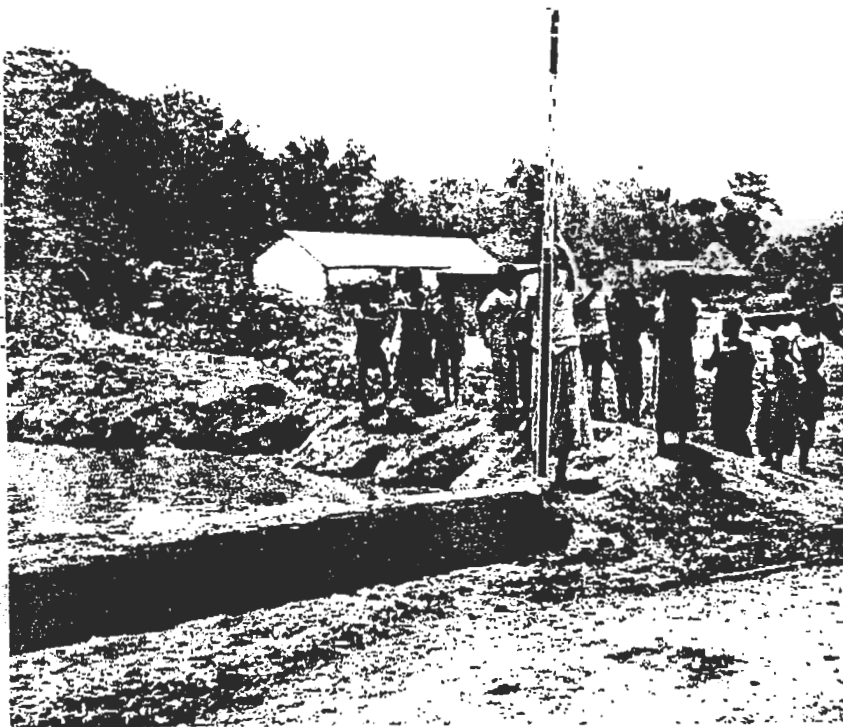

BM 8
ELEVATION 66.665

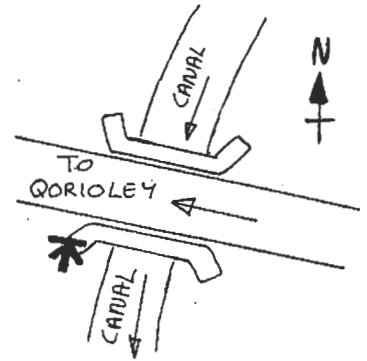

DESCRIPTION

BM 8 is on the centreline of the downstream culvert headwall at the western end.

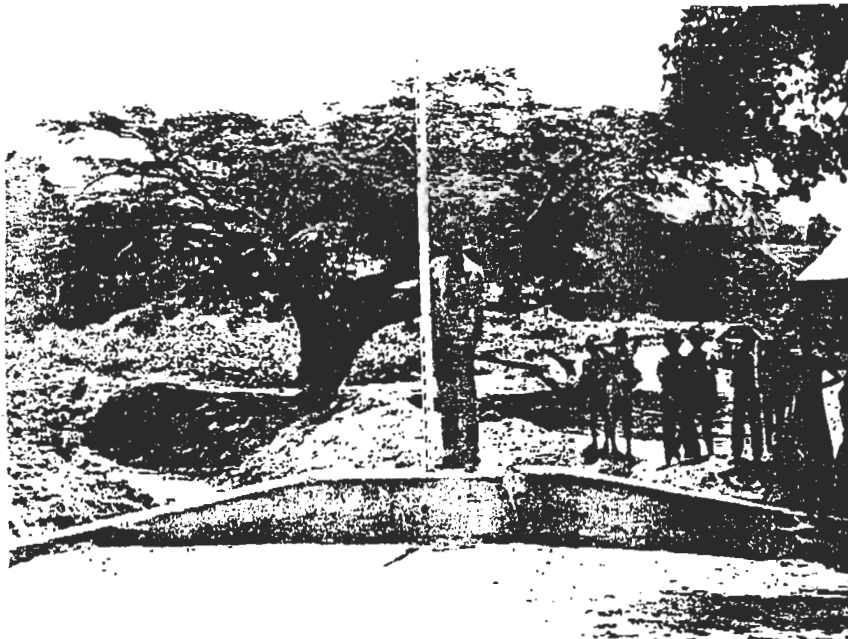

BM 9
ELEVATION 66.783

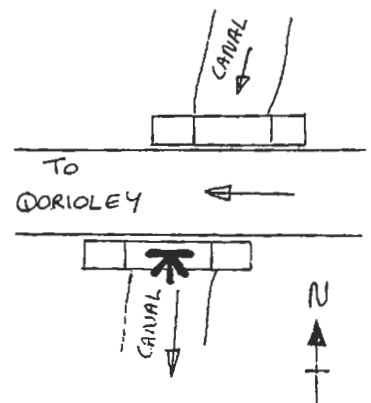

DESCRIPTION

BM 9 is on the centreline of the downstream culvert headwall at the centre.

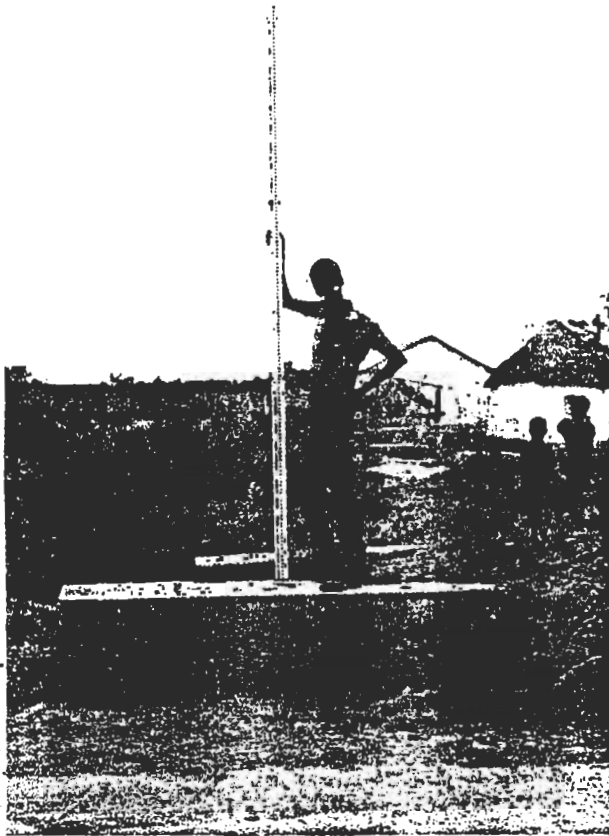

BM 10
 ELEVATION 66.434

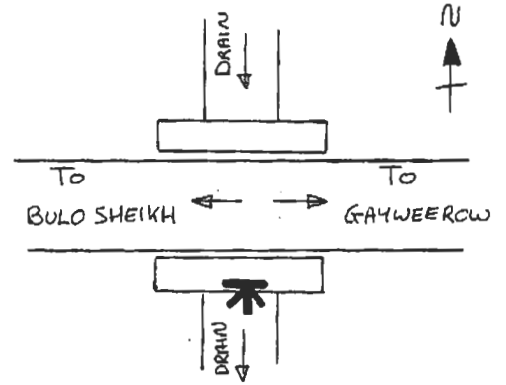

DESCRIPTION

BM 10 is on the downstream edge of the downstream culvert headwall at the centre.

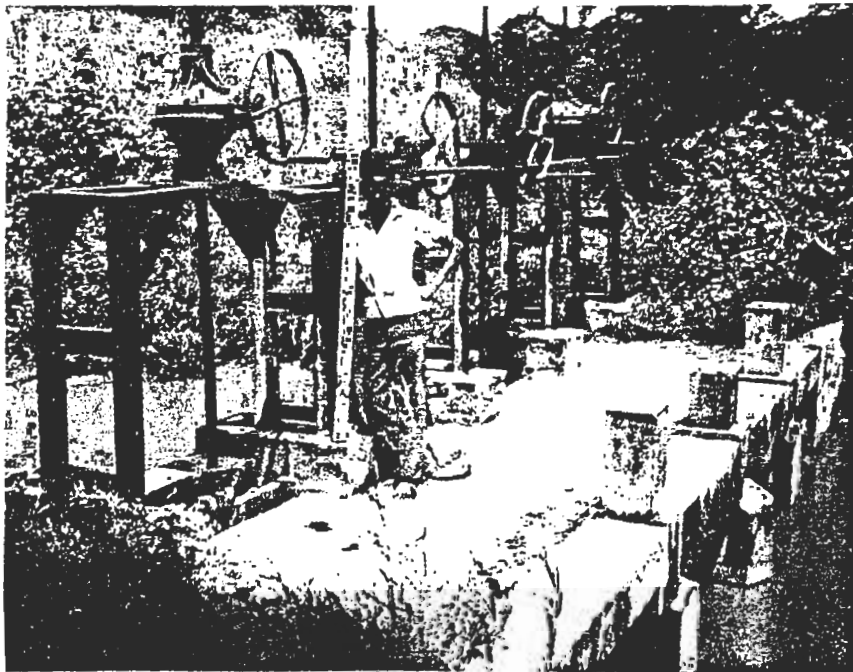

BM 11
 ELEVATION 69.151

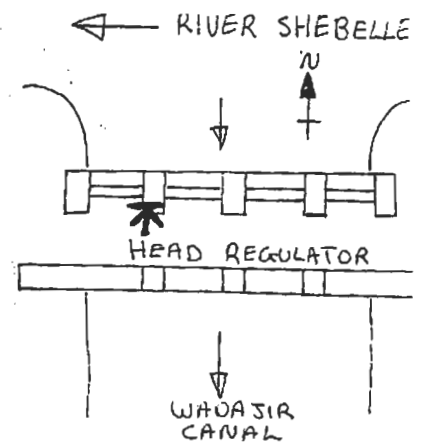

DESCRIPTION

BM 11 is on the south west corner of the second upstream concrete column of the Wadajir canal head regulator.

BM 12

ELEVATION 68.941

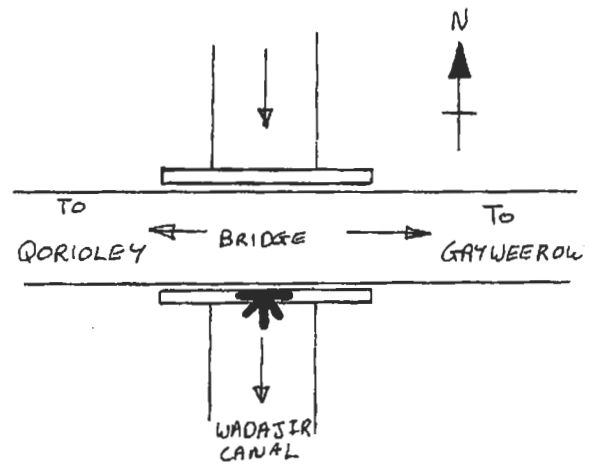
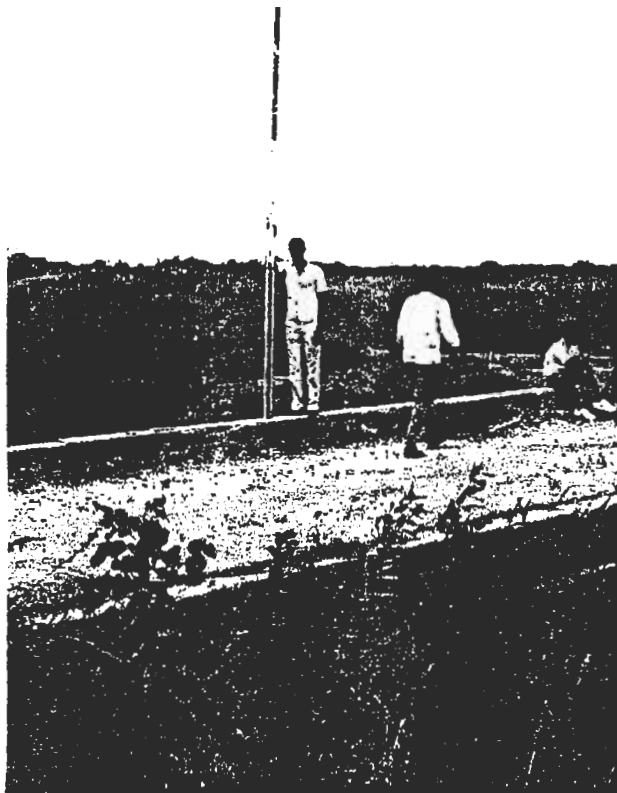

DESCRIPTION

BM 12 is on the centreline of the downstream bridge headwall at the centre.

BM 13

ELEVATION 68.937

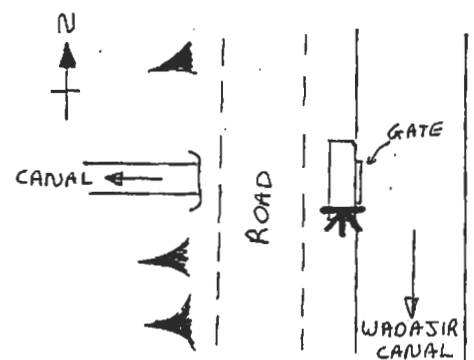
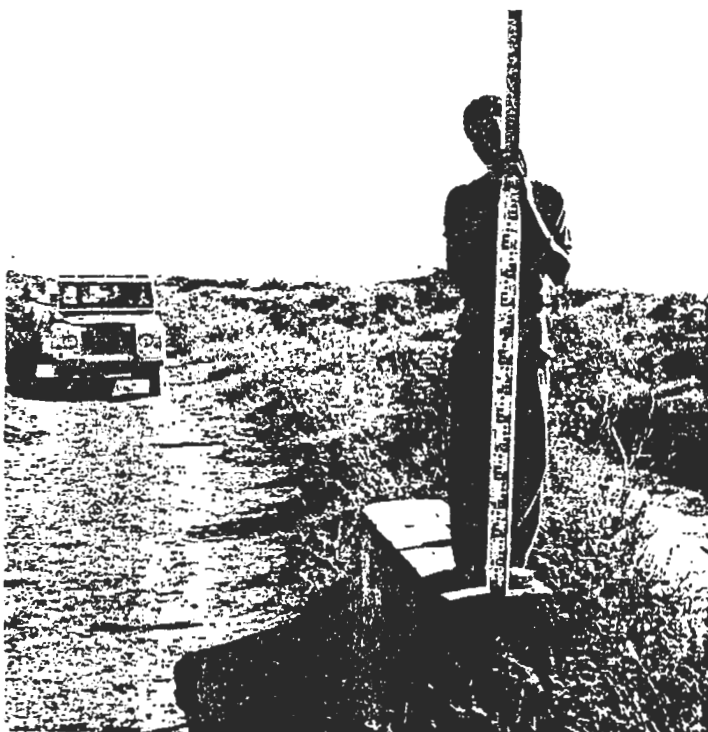

DESCRIPTION

BM 13 is on the centreline of the offtake headwall at the southern end.

FARAHAANE IRRIGATION REHABILITATION PROJECT
REGISTER OF PERMANENT BENCHMARKS

FIGURE A.9

DATUM: 1963 Mean Sea Level, Mogadishu
DATE OF LEVELLING: November 1987

BM 14

ELEVATION 69.161

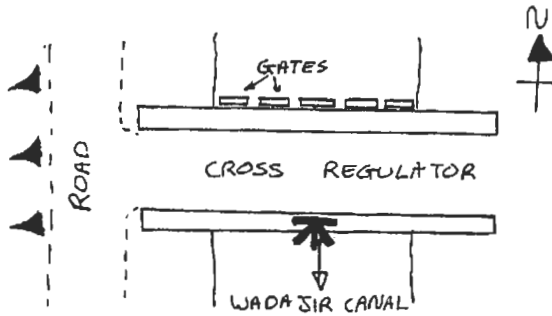

DESCRIPTION

BM 14 is on the centreline of the downstream cross regulator headwall at the centre

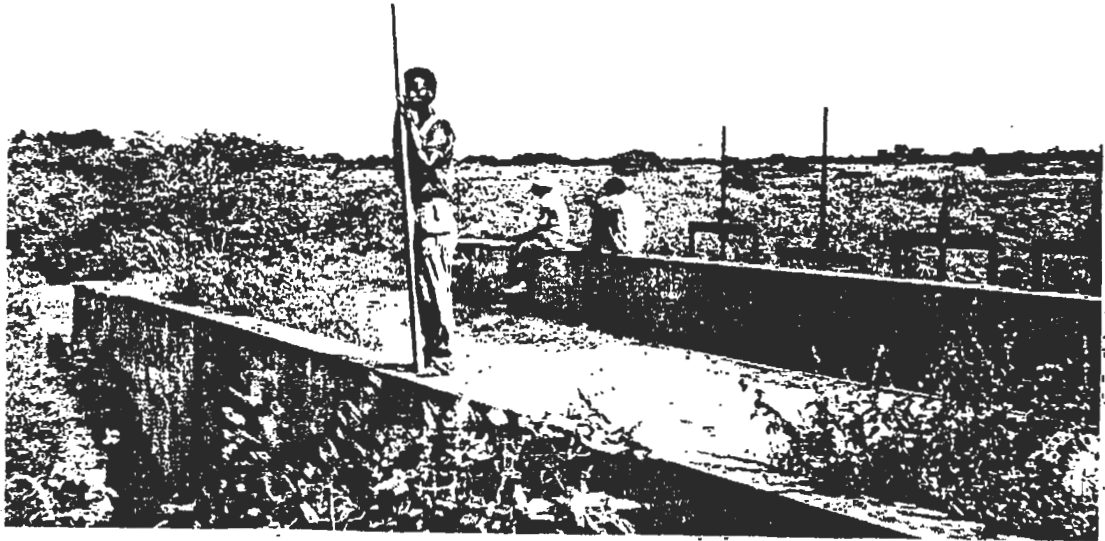

BM 15

ELEVATION 67.691

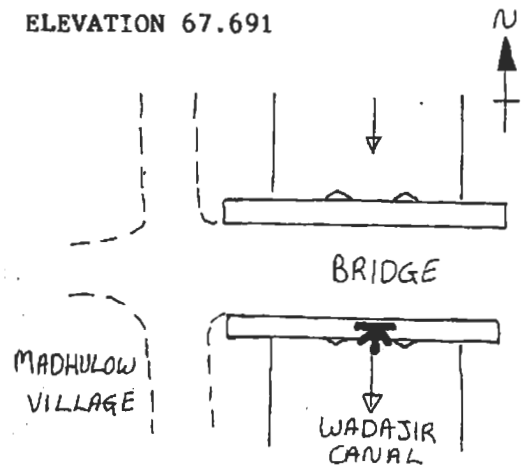

DESCRIPTION

BM 15 is on the centreline of the downstream bridge headwall at the centre. NB the capping on top of the headwall has been destroyed.



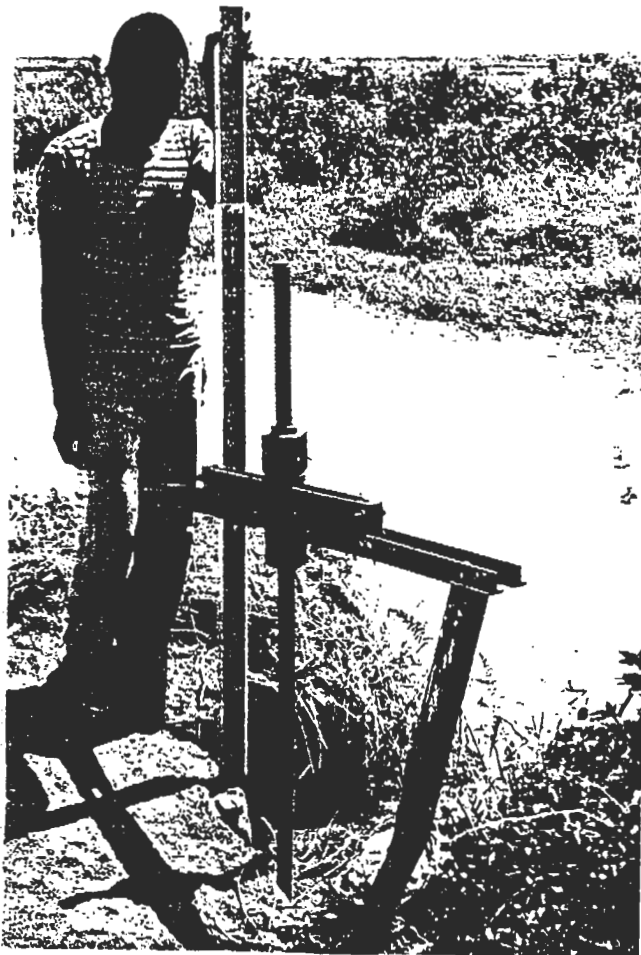

BM 16
 ELEVATION 66.640

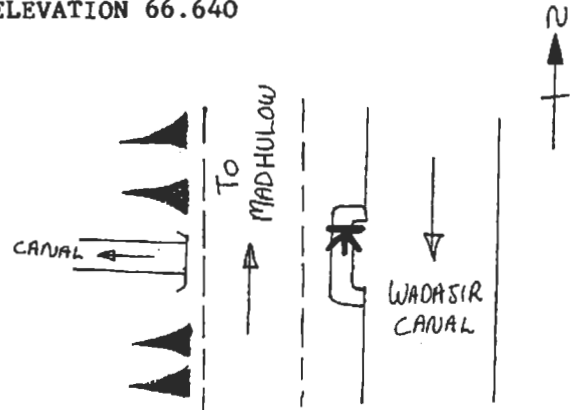

DESCRIPTION

BM 16 is on the centreline of the remains of the concrete offtake headwall at the northern end.

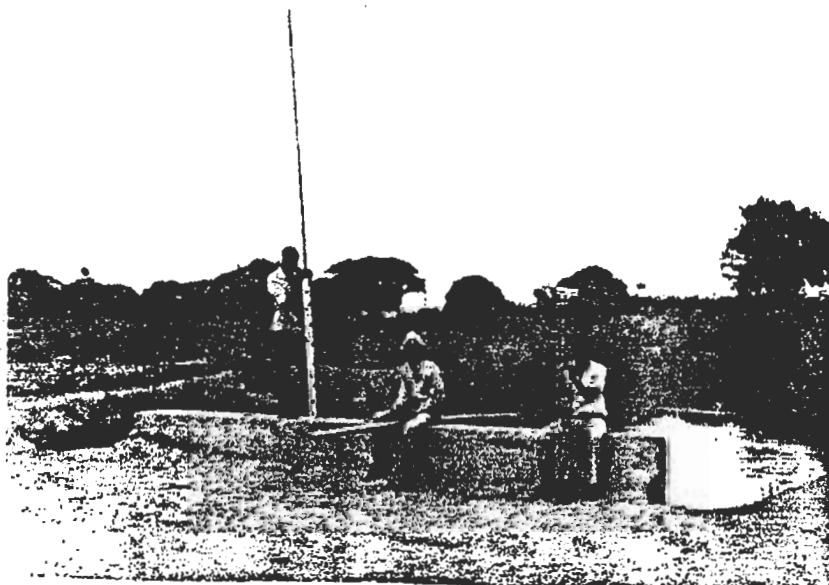

BM 17
 ELEVATION 67.802

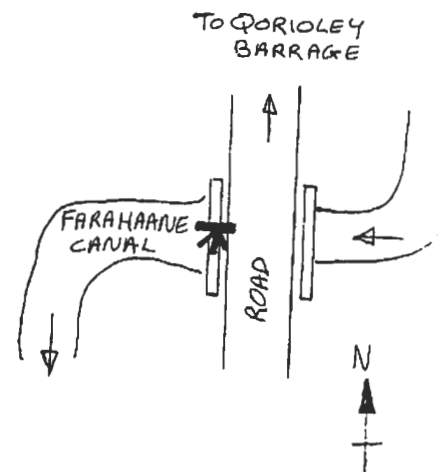

DESCRIPTION

BM 17 is on the centreline of the downstream culvert headwall at the centre.

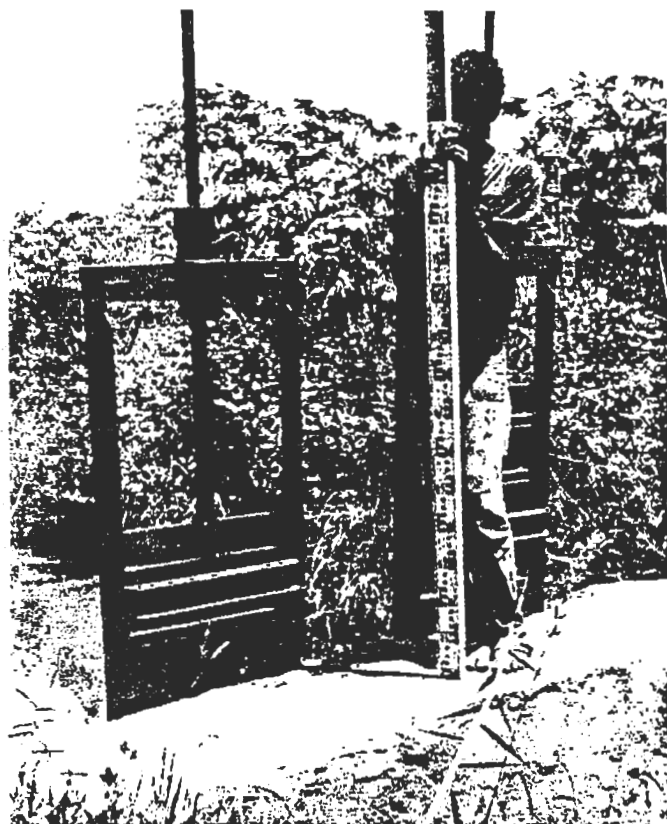

BM 18
 ELEVATION 67.314

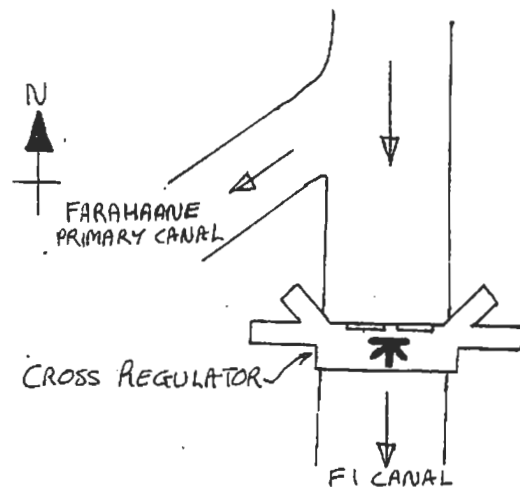

DESCRIPTION

BM 18 is on the centreline of the middle section of the concrete cross-regulator at the centre.

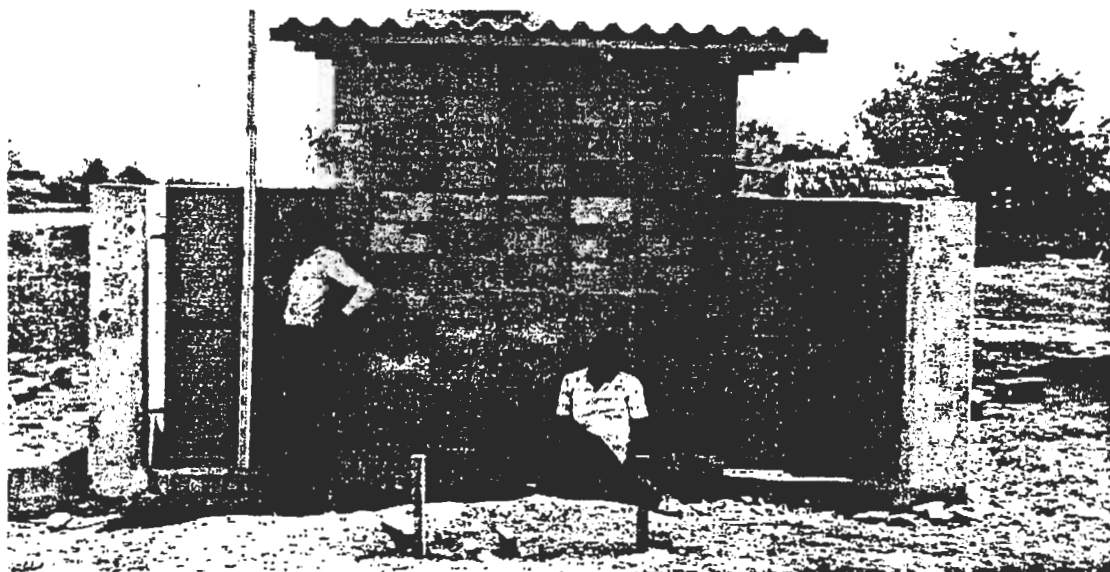

BM 19
 ELEVATION 65.543

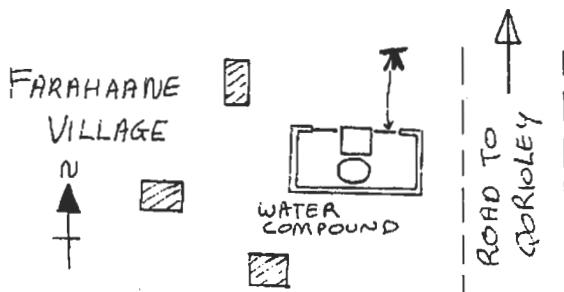

DESCRIPTION

BM 19 is on the centreline of the east side concrete doorstep of the water compound in Farahaane village.

BM 20

ELEVATION 67.164

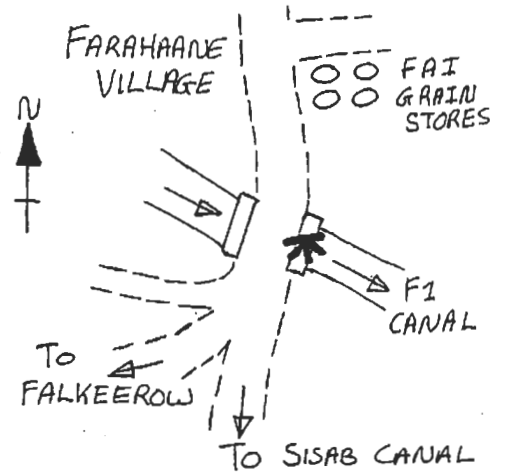
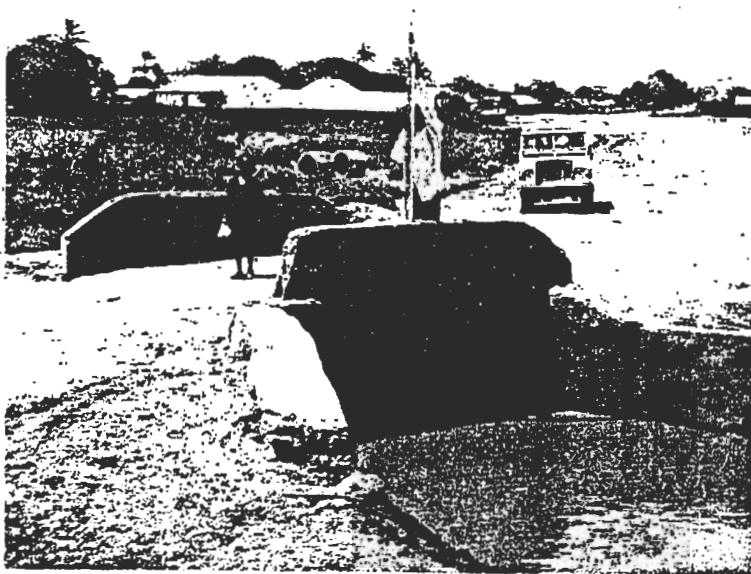

DESCRIPTION

BM 20 is on the centreline of the downstream culvert headwall at the centre.

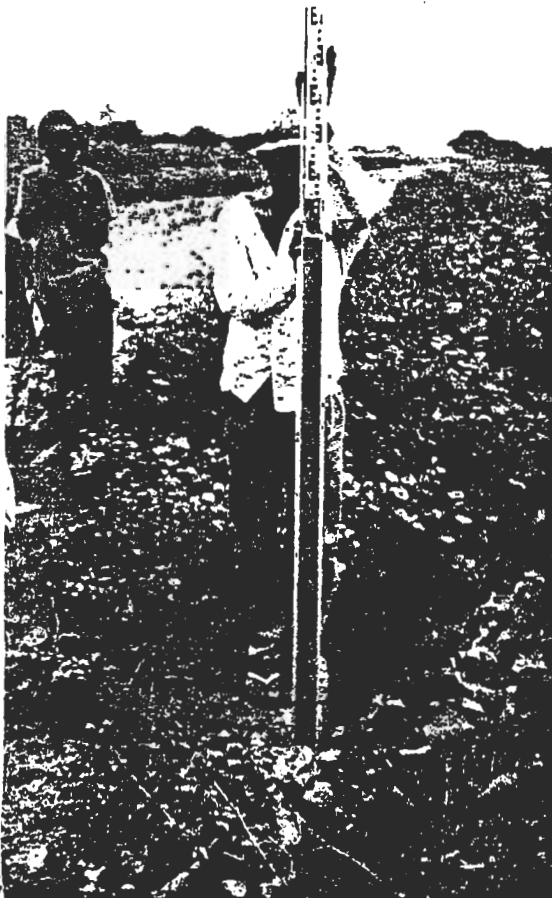

BM 21

ELEVATION 64.832

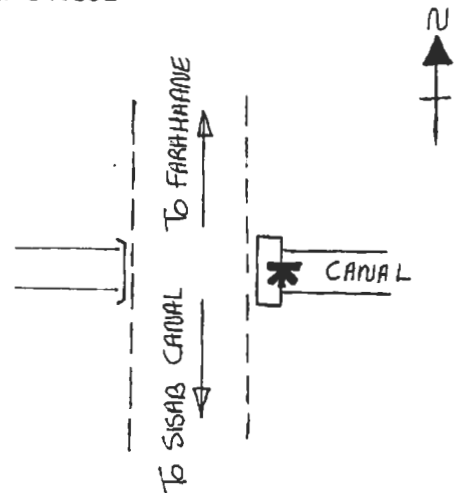

DESCRIPTION

BM 21 is on the eastern edge of the east side culvert headwall at the centre.

BM 22

ELEVATION 65.907

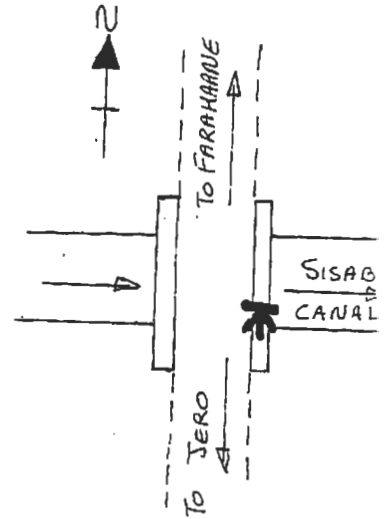

DESCRIPTION

BM 22 is on top of exposed steel bar on top of the downstream bridge headwall.



BM 23

ELEVATION 65.845

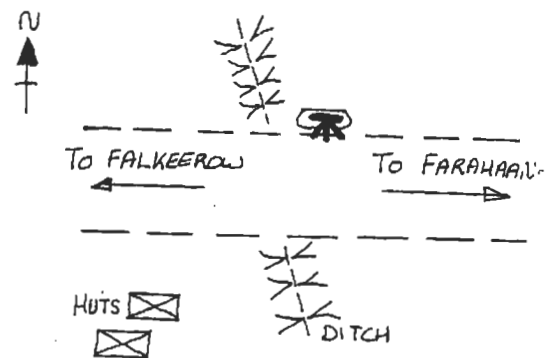

DESCRIPTION

BM 23 is on top of rock on north side of road which is a bit loose.

FARAHAANE IRRIGATION REHABILITATION PROJECT
 REGISTER OF PERMANENT BENCHMARKS
 DATUM: 1963 Mean Sea Level, Mogadishu
 DATE OF LEVELLING: November 1987

FIGURE A.14



BM 24
 ELEVATION 66.113

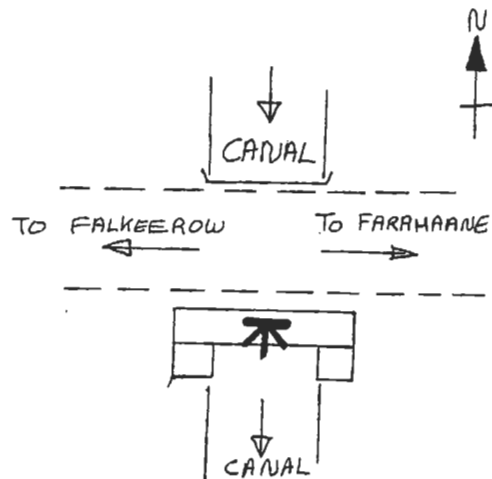

DESCRIPTION

BM 24 is on the centreline of the downstream culvert headwall at the centre.



BM 25
 ELEVATION 65.234

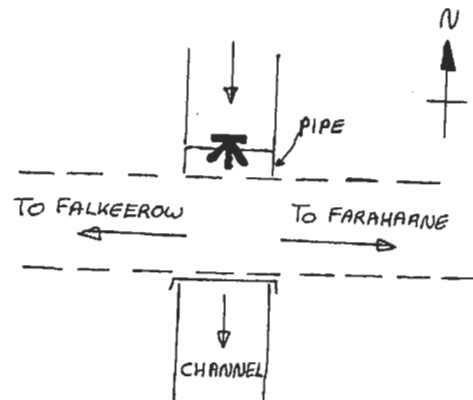

DESCRIPTION

BM 25 is on the centreline of the top exterior surface of the concrete pipe on the northern edge.

FARAHAANE IRRIGATION REHABILITATION PROJECT
 REGISTER OF PERMANENT BENCHMARKS
 DATUM: 1963 Mean Sea Level, Mogadishu
 DATE OF LEVELLING: November 1987

FIGURE A-15

BM 26

ELEVATION
 64.856

DESCRIPTION

BM 26 is on top of the highest point on the northern headwall of broken culvert.

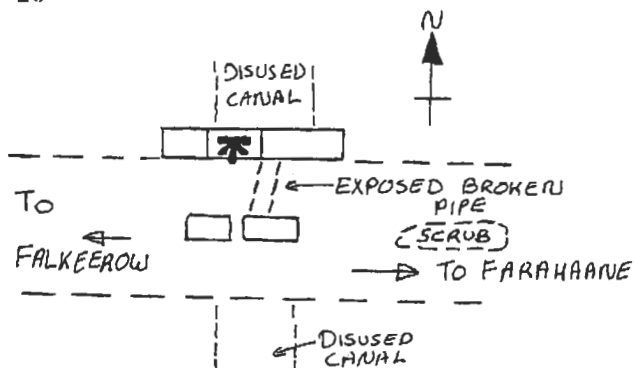

BM 27

ELEVATION
 67.153

DESCRIPTION

BM 27 is on the centreline of the downstream left bank concrete abutment wall at the western edge.

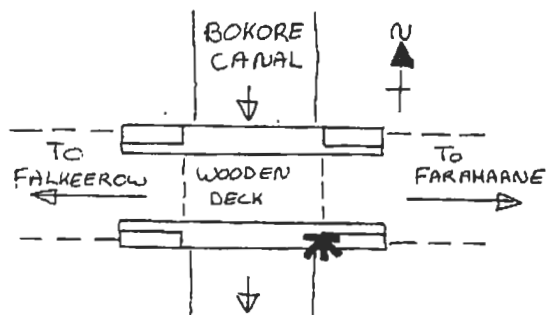

FARAHANE IRRIGATION REHABILITATION PROJECT
 REGISTER OF PERMANENT BENCHMARKS
 DATUM: 1963 Mean Sea Level, Mogadishu
 DATE OF LEVELLING: November 1987

FIGURE A.16

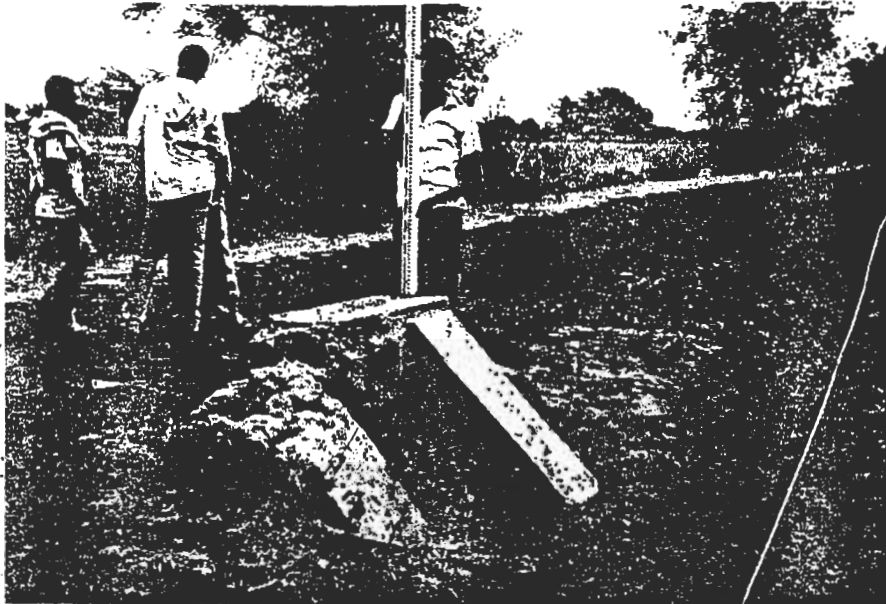

BM 28

ELEVATION 64.832

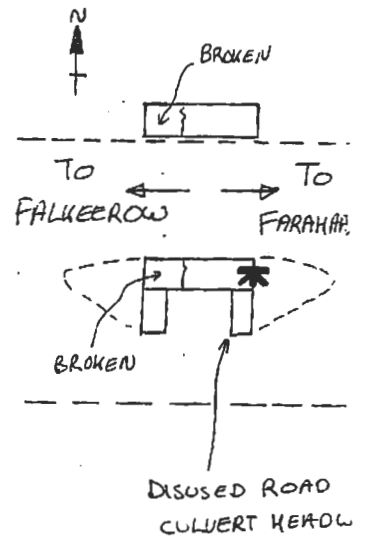

DESCRIPTION

BM 28 is on the centreline of the south disused road culvert headwall at the eastern edge.



BM 29

ELEVATION 66.656

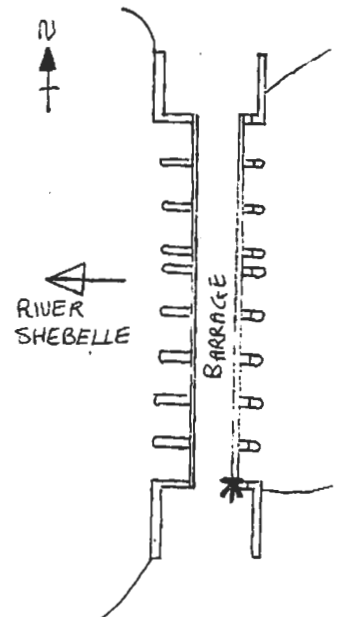

DESCRIPTION

Falkeerow Barrage

BM 29 is on the eastern edge of the road curb adjacent to the centreline of the upstream left bank column.

FARAHAANE IRRIGATION REHABILITATION PROJECT
REGISTER OF PERMANENT BENCHMARKS

DATUM: 1963 Mean Sea Level, Mogadishu

DATE OF LEVELLING: November 1987

FIGURE A.17

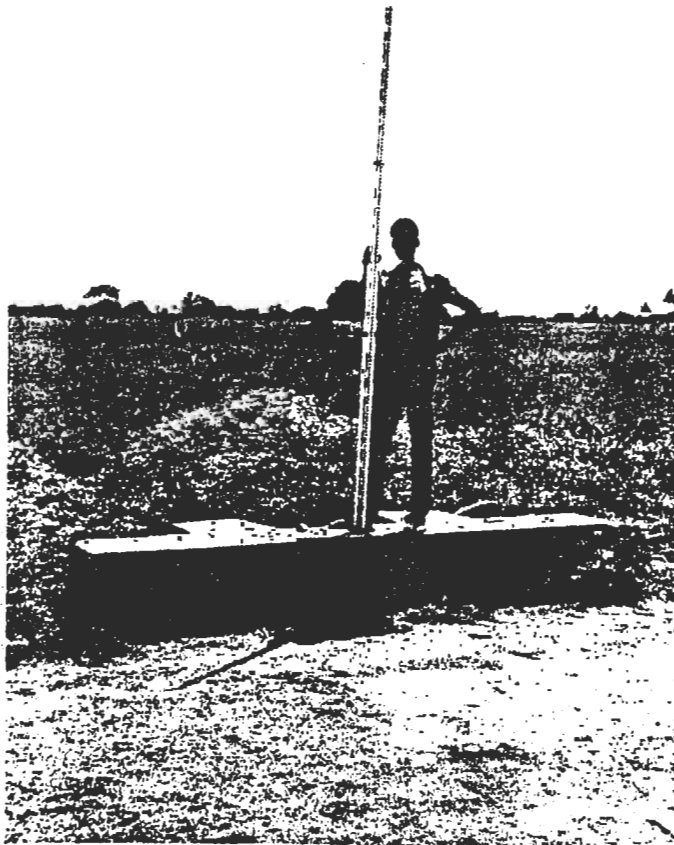

BM 30

ELEVATION 66.713

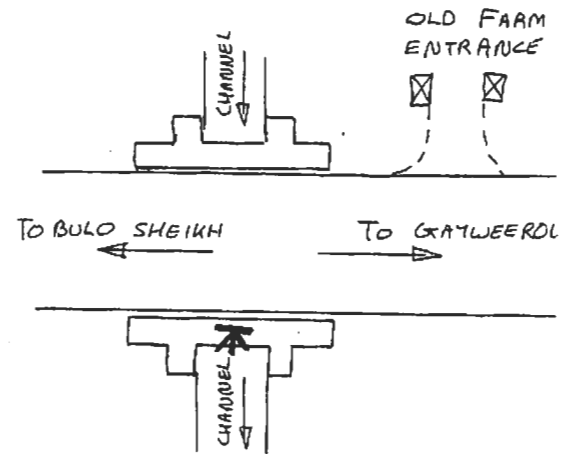

DESCRIPTION

BM 30 is on the centreline of the downstream culvert headwall at the centre.

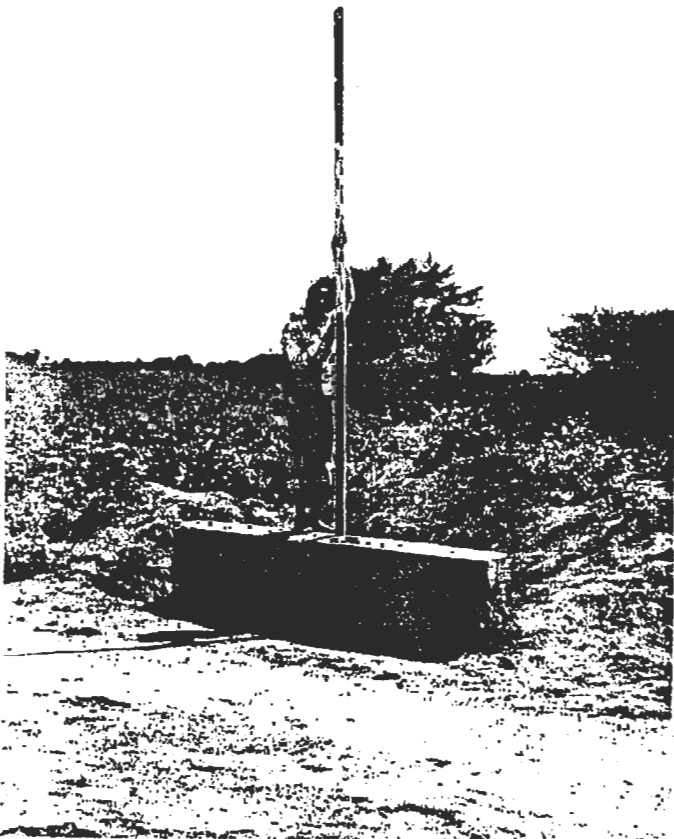

BM 31

ELEVATION 67.337

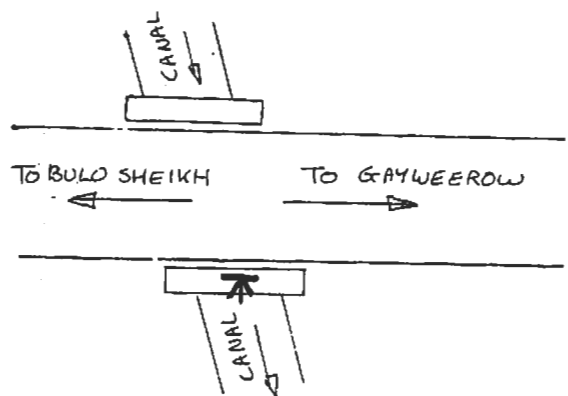

DESCRIPTION

BM 31 is on the centreline of the downstream culvert headwall at the centre.

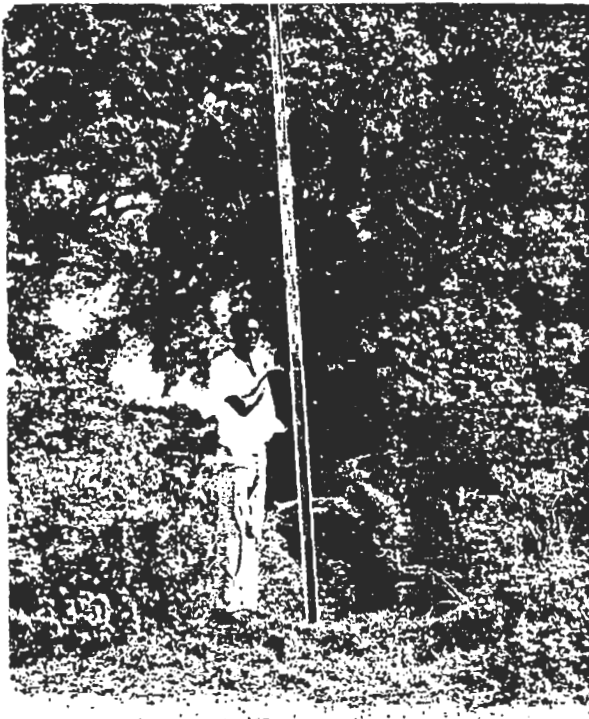

BM 32
 ELEVATION 68.595

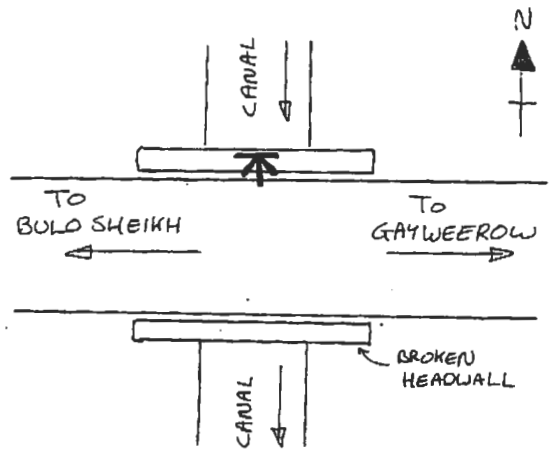

DESCRIPTION

BM 32 is on the centreline of the upstream culvert headwall at the centre.

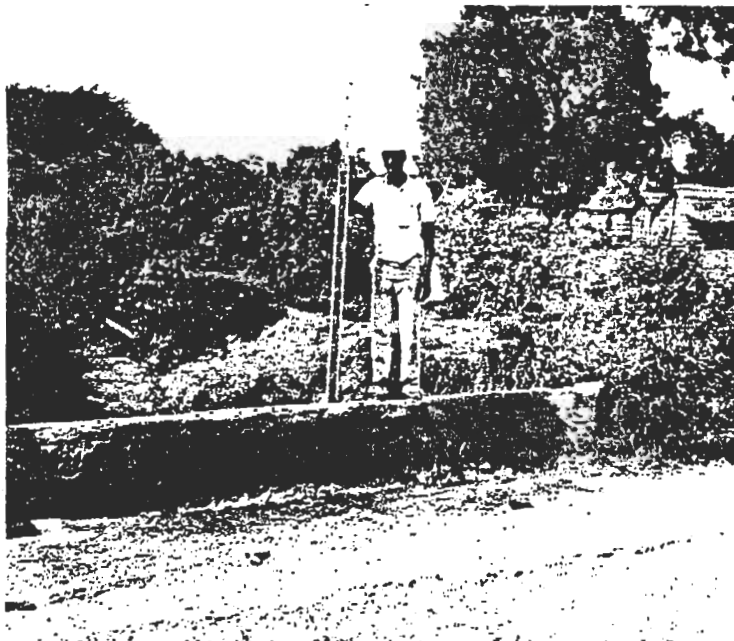

BM 33
 ELEVATION 69.471

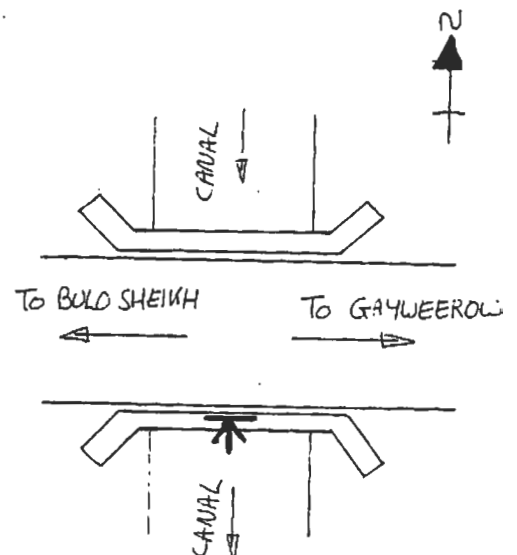

DESCRIPTION

BM 33 is on the centreline of the downstream culvert headwall at the centre.

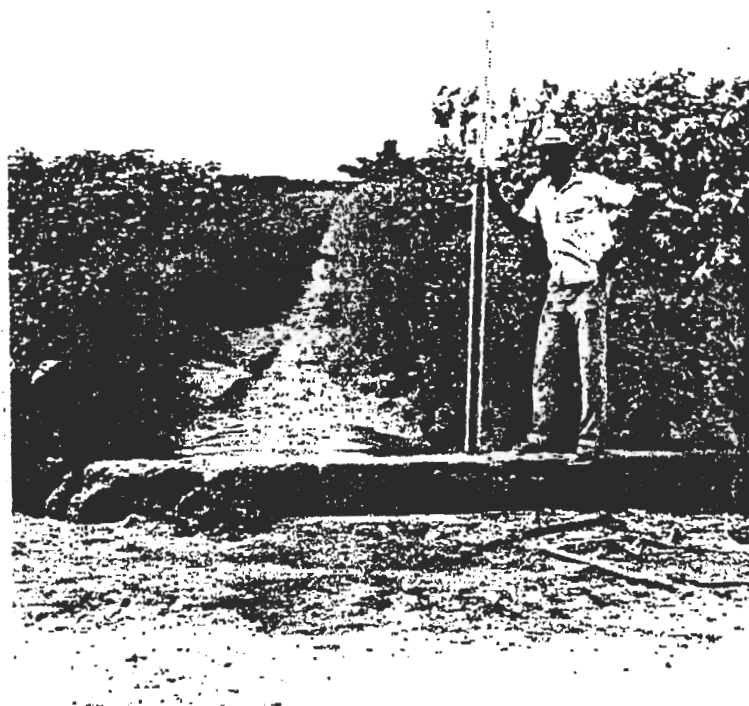

BM 34

ELEVATION 69.249

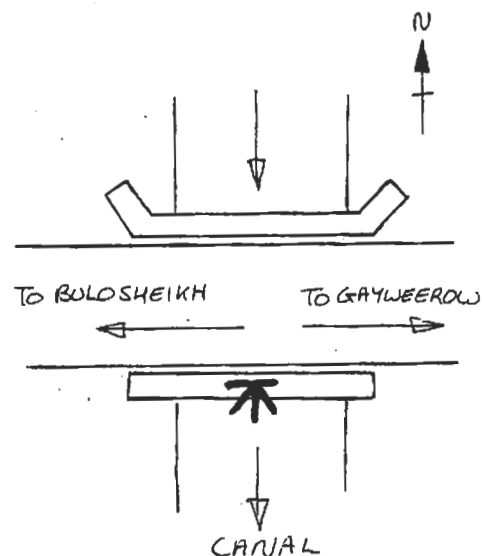

DESCRIPTION

BM 34 is on the centreline of the downstream culvert headwall on top of exposed metal loop.

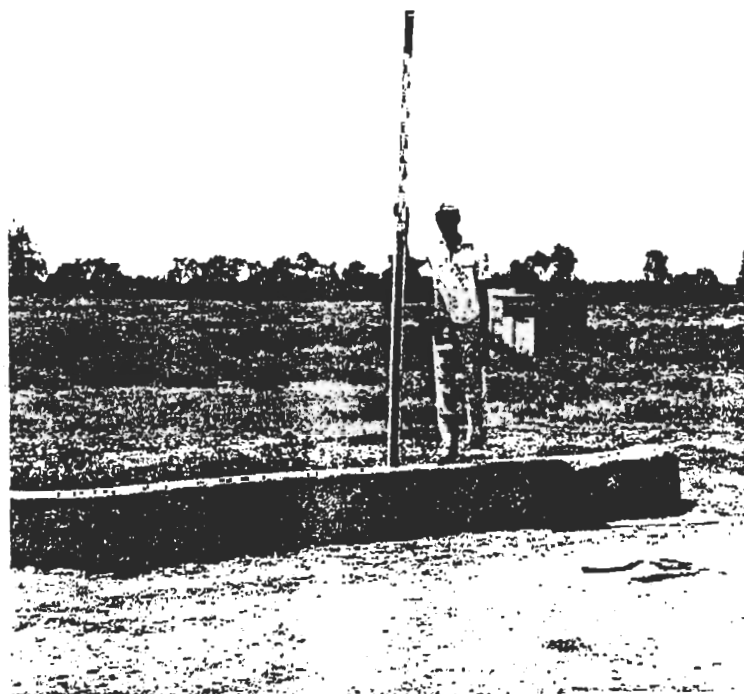

BM 35

ELEVATION 69.835

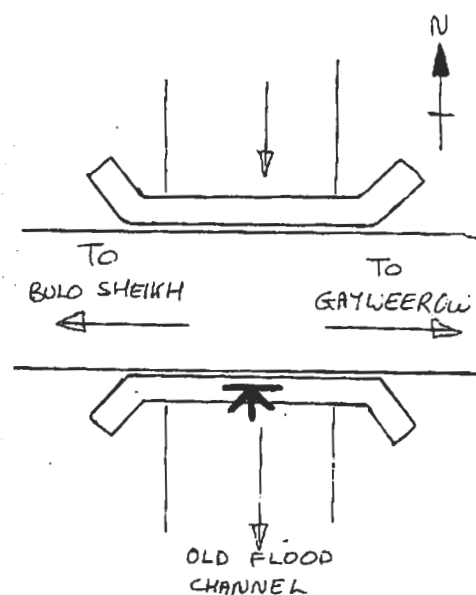

DESCRIPTION

BM 35 is on the centreline of the downstream culvert headwall at the centre.

BM 36

ELEVATION 70.033

DESCRIPTION

BM 36 is on the centreline of the upstream left bank concrete abutment wall at the east end adjacent to the end handrail post.

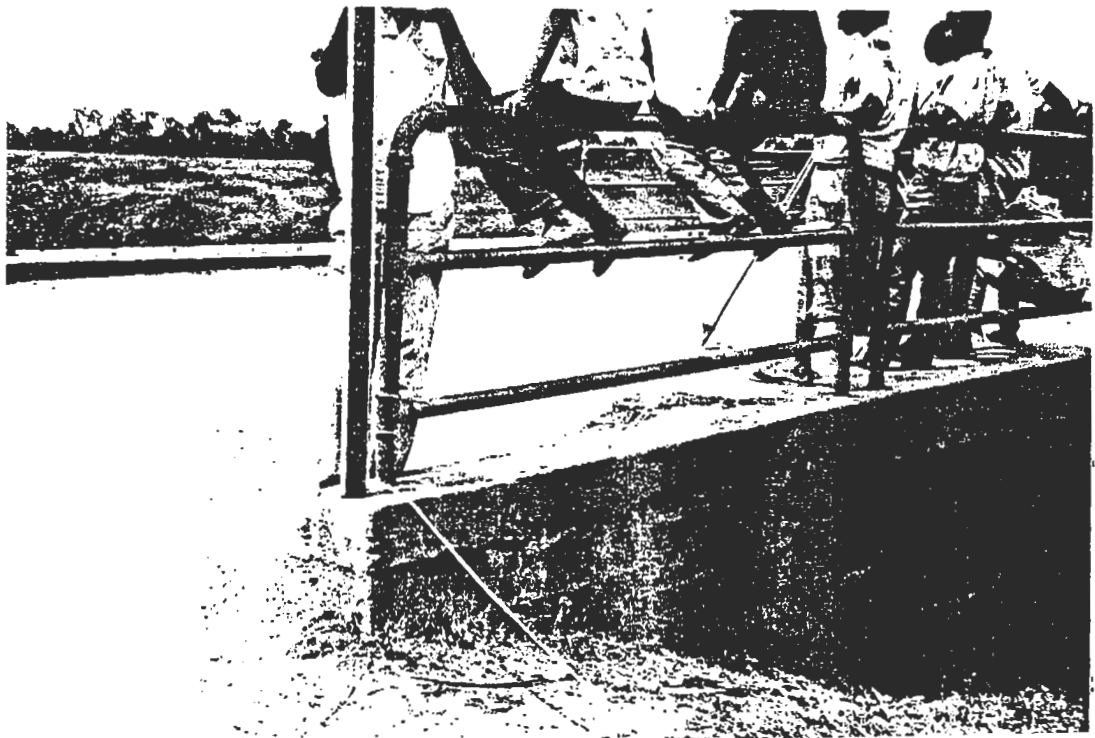
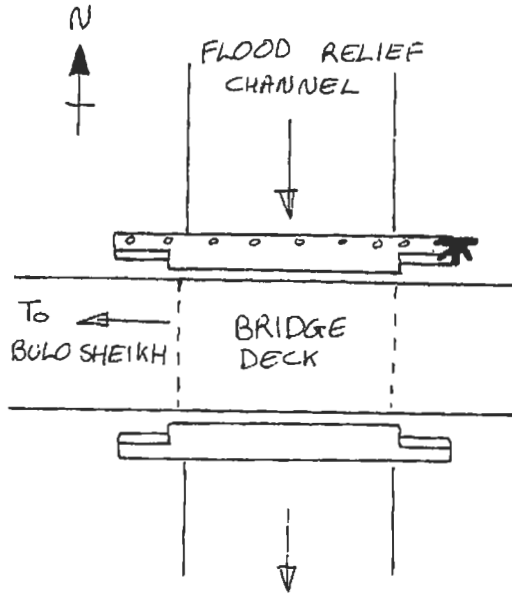

BM 37

ELEVATION 70.649

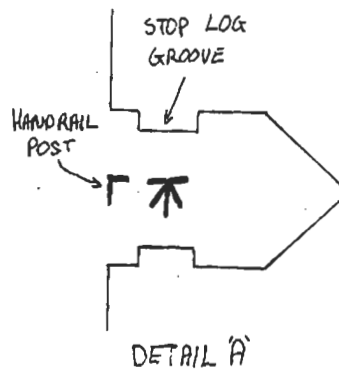
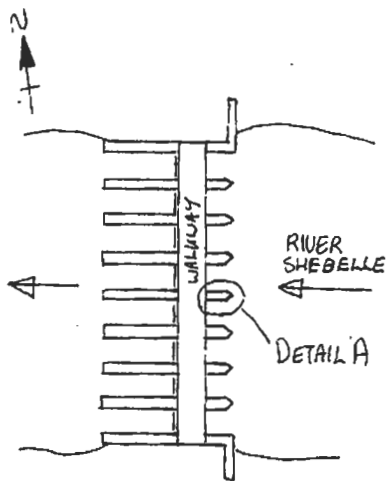
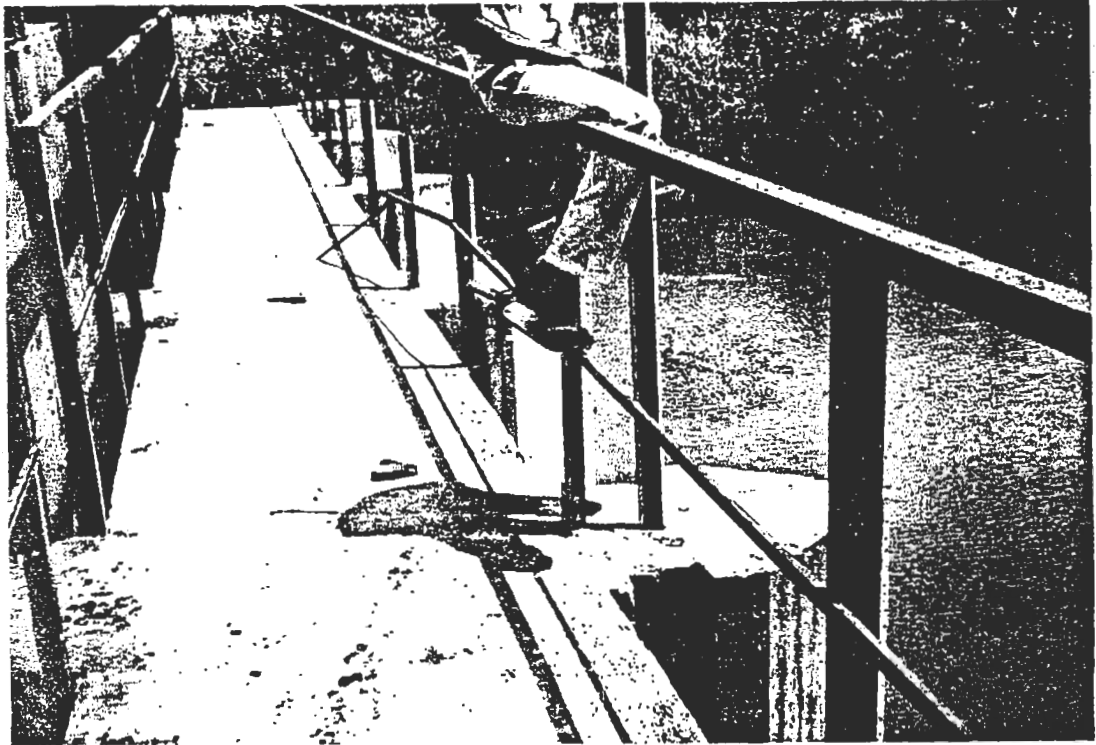

DESCRIPTION

Gayweerow Barrage
BM 37 is on the
centreline of the
middle upstream con-
crete pier between
the stop log grooves.



BM 38

ELEVATION 71.352

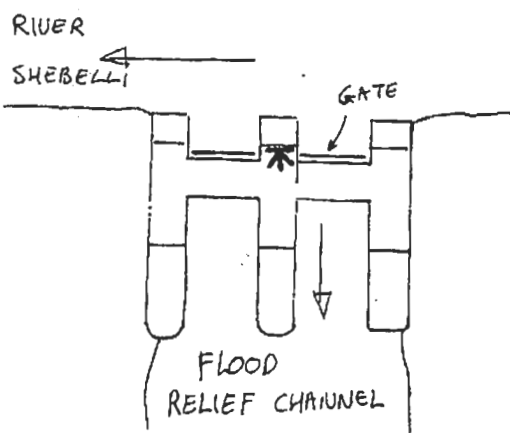
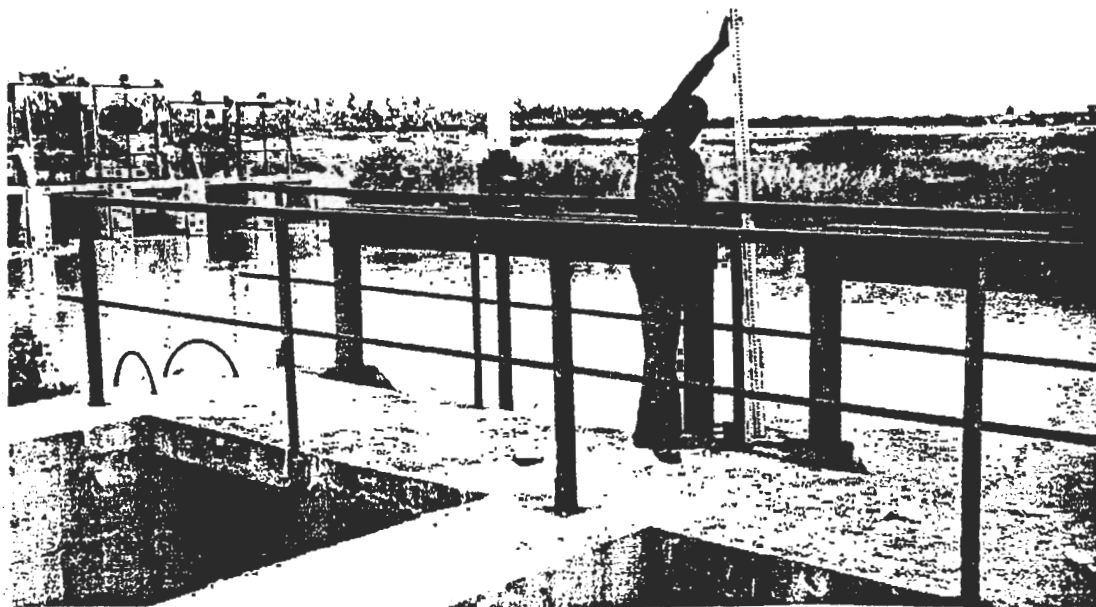

DESCRIPTION

Flood Relief Channel Headworks
 BM 38 is on the centreline of the middle upstream pier between the gates.

BM 39

ELEVATION 66.693

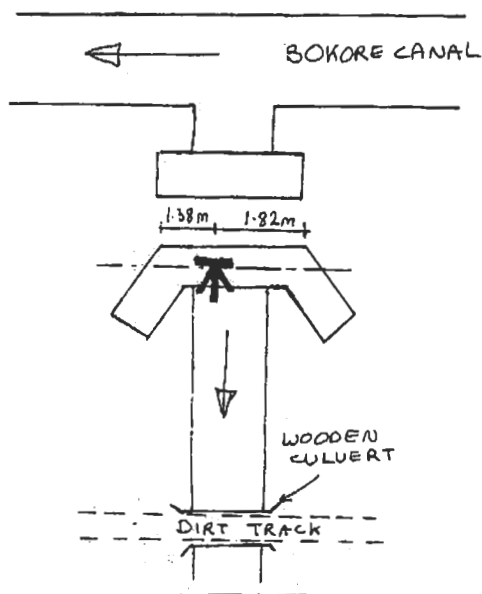

DESCRIPTION

BM 39 is on the centreline of the downstream head regulator headwall at 22 cm off-centre towards the right bank. The head regulator is 1 000 m from BM 27 measured along Bokore Canal.

BM 40

ELEVATION 65.633

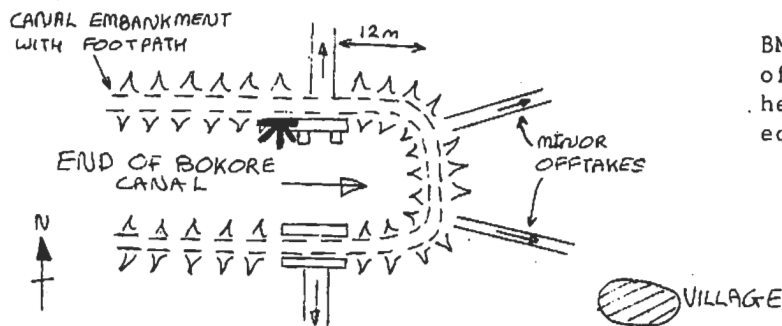
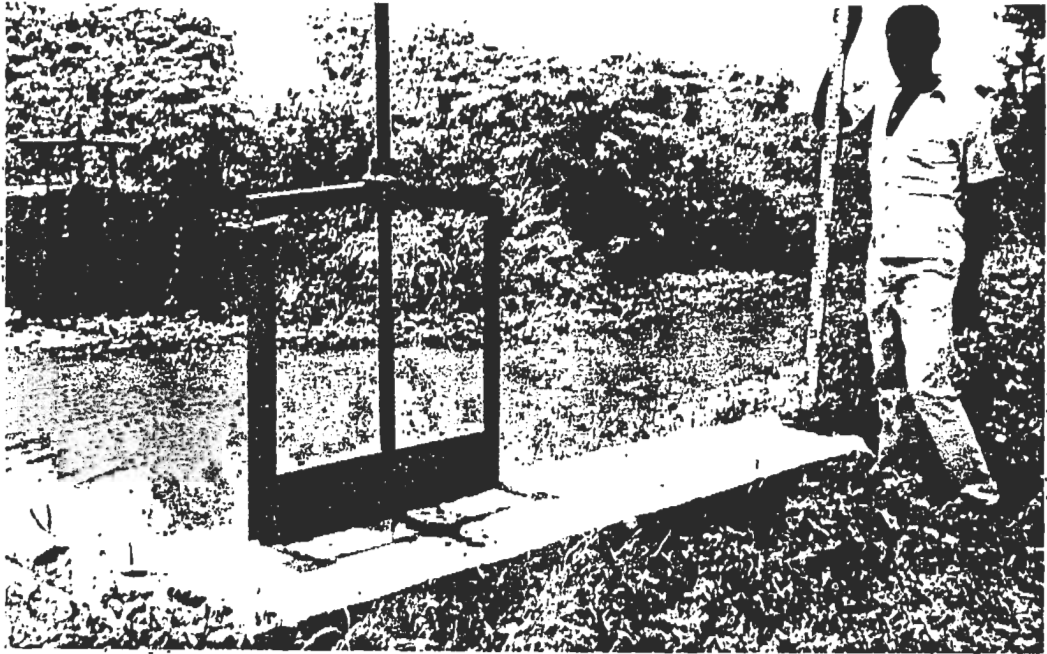

DESCRIPTION

BM 40 is on the centreline of the left bank offtake headwall at the western edge.

BM 41

ELEVATION 64.976

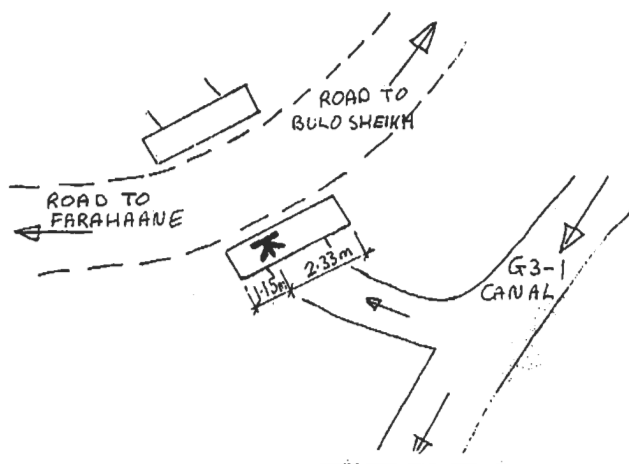

DESCRIPTION

BM 41 is on the centreline of the upstream road culvert headwall at 59 cm off-centre towards the left bank. The culvert is 2.75 km from Farahaane along the unsurfaced road to Bulu Sheikh on a 90° bend.

BM 42

ELEVATION 64.942

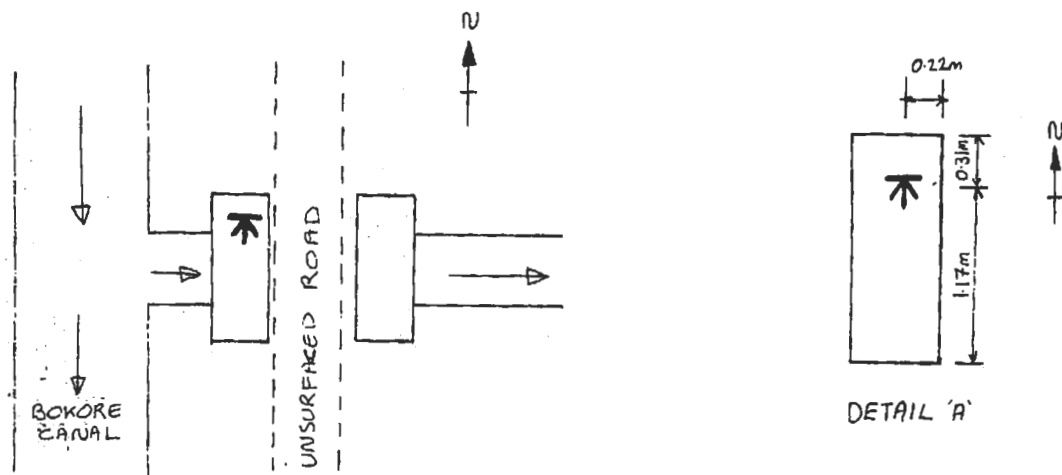

DESCRIPTION

BM 42 is on the upstream road culvert headwall as shown in detail 'A'. The culvert is at chainage 2.4 km south from BM 27 measured along the Bokore canal.

BM 45

ELEVATION 68.559

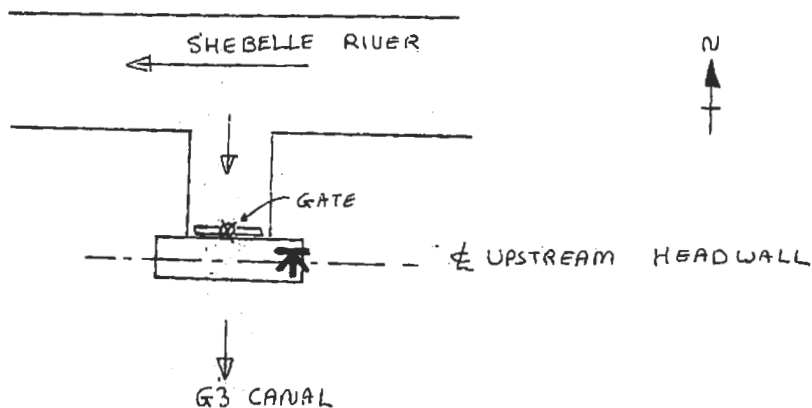

DESCRIPTION

BM 45 is on the centreline of the G3 canal head regulator upstream canal head regulator upstream concrete headwall at the eastern edge.

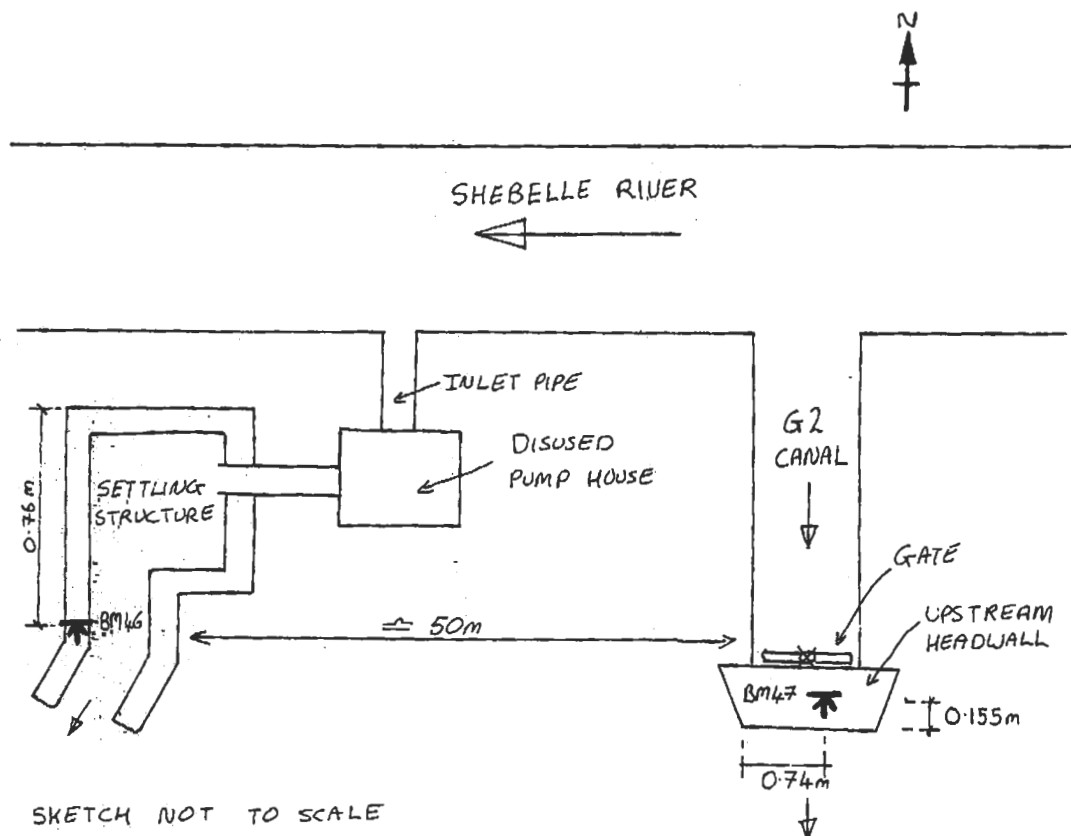

BM 46

ELEVATION 68.899

DESCRIPTION

BM 46 is on top of the centreline of the western wall of the disused settling structure as shown in sketch.

BM 47

ELEVATION 68.856

DESCRIPTION

BM 47 is on the G2 canal head regulator upstream concrete headwall as shown in sketch.

BM 48

ELEVATION 68.071

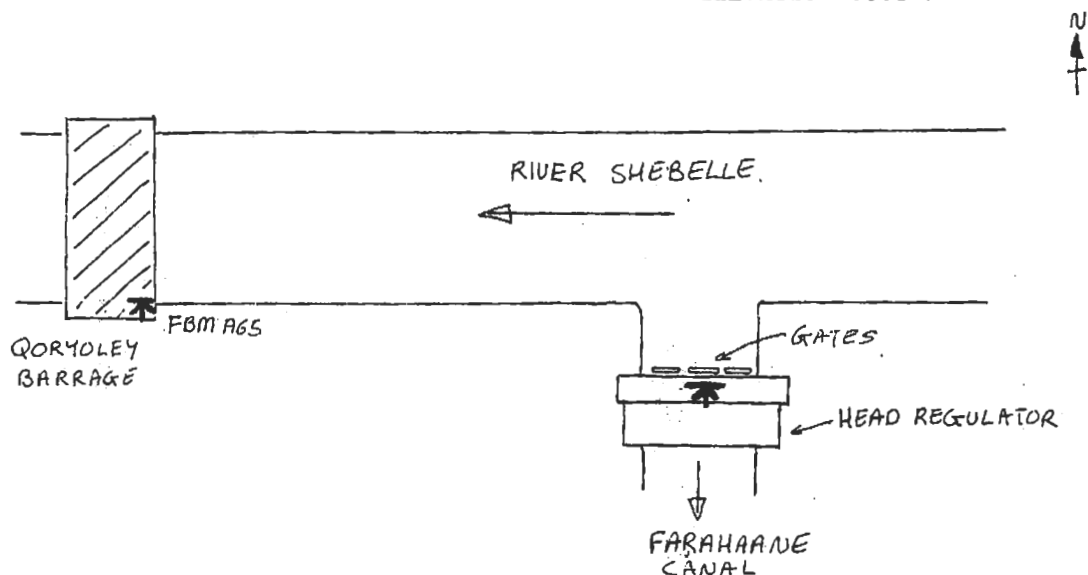

DESCRIPTION

BM 48 is on the centreline of the Farahaane canal head regulator upstream concrete headwall at the centre.

BM 49

ELEVATION 65.683

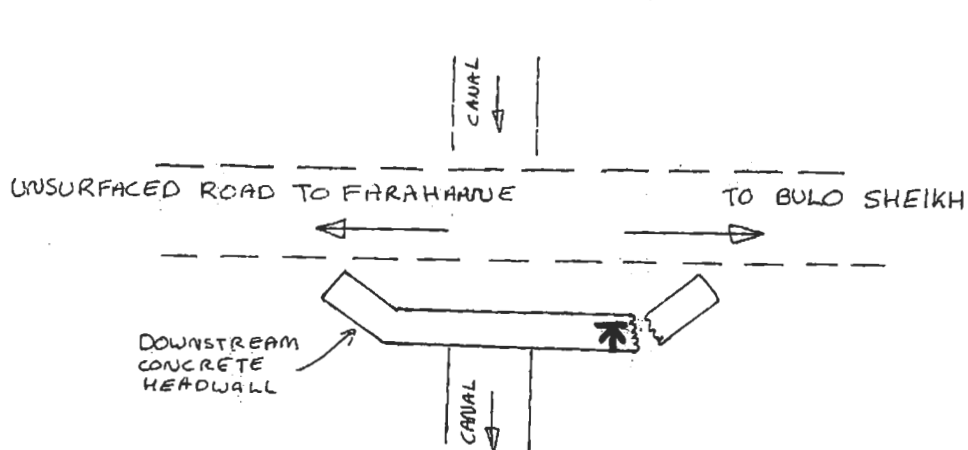

DESCRIPTION

BM 49 is on the centreline of the downstream road culvert headwall at the western side of the large crack. The road culvert is 1.7km from Farahaane village.



BM 50
 ELEVATION 65.522

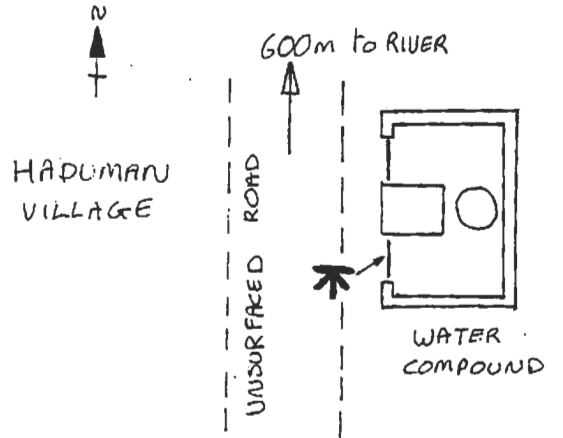

DESCRIPTION

BM 50 is on the centreline of the south side concrete doorstep of the water compound in Haduman village in front of the closed metal door.



BM 51
 ELEVATION 67.145

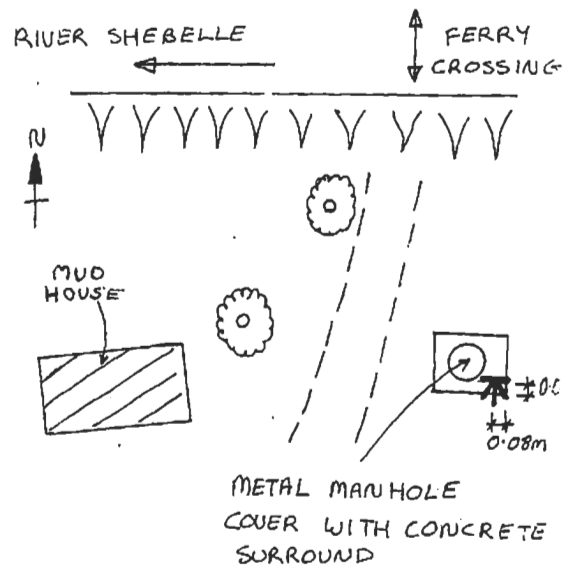

DESCRIPTION

BM 51 is on the south east corner of the concrete manhole surround near the river Shebelle in Haduman.

BM 53

ELEVATION 67.055

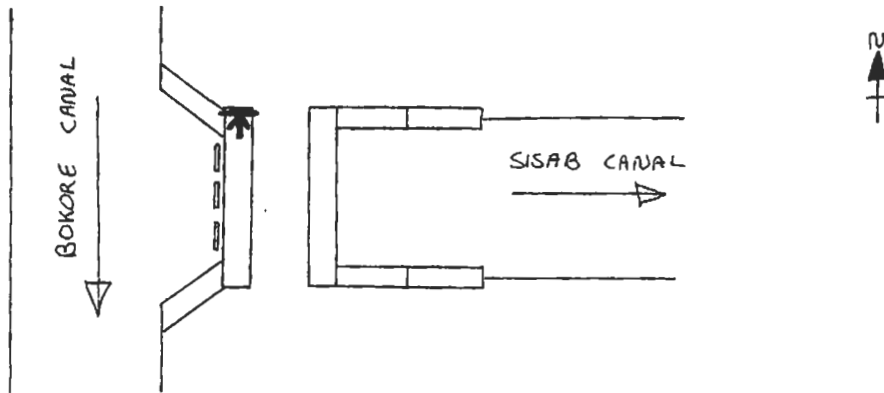

DESCRIPTION

BM 53 is on the centreline of the Sisab canal head regulator upstream headwall at the northern end.

BM 54

ELEVATION 66.371

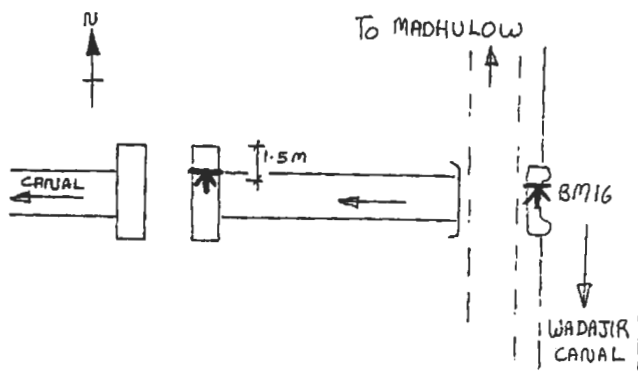
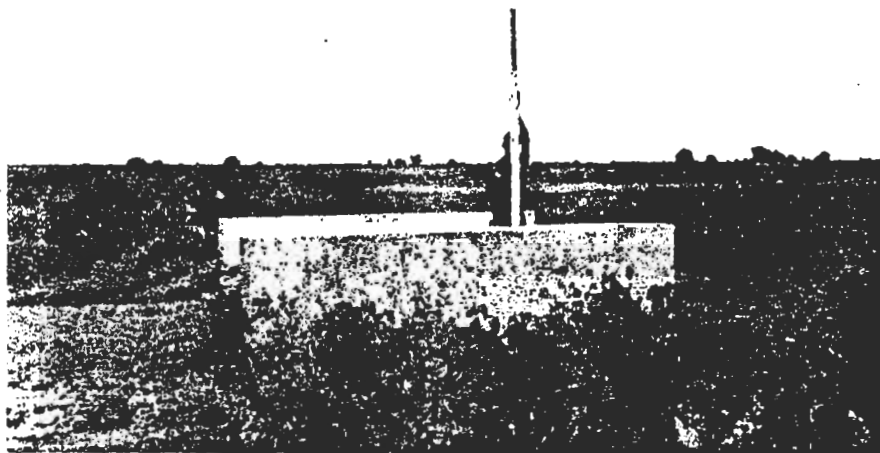

DESCRIPTION

BM 54 is on the centre-line of the upstream concrete headwall at 1.5 m from the northern edge.

FARAHAAANE IRRIGATION REHABILITATION PROJECT
 REGISTER OF PERMANENT BENCHMARKS
 DATUM: 1963 Mean Sea Level, Mogadishu
 DATE OF LEVELLING: November 1987

FIGURE A.29



BM 55
 ELEVATION 66.495

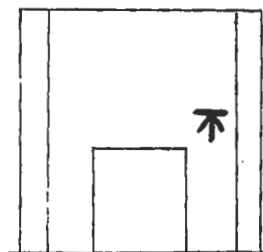
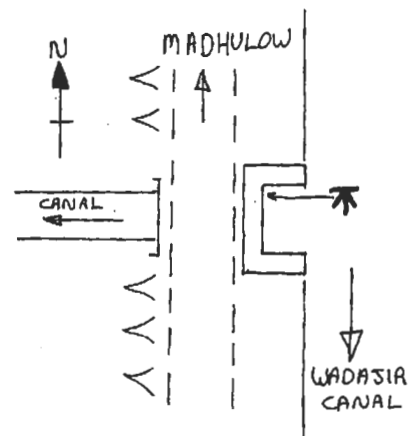

ELEVATION OF UPSTREAM
 FACE OF OFFTAKE

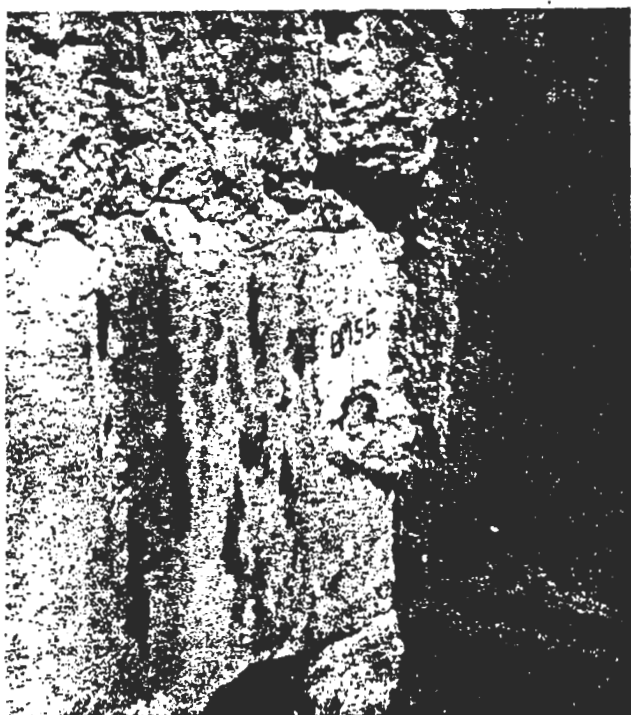

DESCRIPTION

BM 55 is on a ledge on the upstream face of the offtake headwall. The ledge is approximately 0.7 m below the top of the headwall at the northern side. The offtake is 1.7 km south of Madhulow.

APPENDIX B
FARAHANE IRRIGATION REHABILITATION PROJECT
CADASTRE SURVEY
DRAFT MANUAL OF INSTRUCTION FOR
SURVEYORS AND DRAUGHTSMEN

CONTENTS

		Page Nr
1	BACKGROUND	
	1.1 The Cadastre Survey	B-2
	1.2 Object of the Survey	B-2
	1.3 The Field Work	B-2
	1.4 The Office Work	B-2
2	INSTRUCTIONS TO SURVEYORS	
	2.1 General	B-3
	2.2 Survey Procedures	B-4
	2.3 Field Mosaic Sheets	B-4
	2.4 Plot Registration Cards	B-6
	2.5 Administration	B-6
3	INSTRUCTIONS TO DRAUGHTSMEN	
	3.1 General	B-7
	3.2 Plot Boundary Maps	B-7
	3.3 Plot Area Measurement	B-8
	3.4 Plot Area Scheduling	B-10
	3.5 Administration	B-10

FARAAANE CADASTRE SURVEY
MANUAL OF INSTRUCTION
FOR
SURVEYORS AND DRAUGHTSMEN

1 BACKGROUND

- 1.1 The Farahaane Irrigation Rehabilitation Project Cadastral Survey is being carried out by the Ministry of Agriculture.
- 1.2 The object of the Survey is to identify, measure, and record the boundaries of farm-plots within the Project Irrigation Area, together with details of the plot owners, their trees and standing crops. This information will subsequently be used for the purpose of designing the detailed irrigation layout for rehabilitation within the project area.
- 1.3 The Field Work comprises:-
- 1.3.1 Contact by the Ministry of Agriculture Surveyor/enumerator with local residents, farmers, headman, chief etc to obtain indication of plot boundaries on the ground.
 - 1.3.2 Marking of boundaries, and plot numbers on prints of 1:2 000 scale Controlled Photo-Mosaic Sheets, each covering an area of 2.0 x 1.0 km and bearing a unique identification number, in the presence of the plot owners and preferably a representative from the village headman.
 - 1.3.3 Recording simultaneously on printed Farm Plot Registration Cards (see Figure 4.1) the plot-owners' name, village of residence, crops, trees, details of the type of tenure and other plots held.
- 1.4 The Office Work comprises:-
- 1.4.1 Tracing of plot boundaries from the Field Mosaic Sheets to transparencies to create Plot Boundary Maps.
 - 1.4.2 Tracing of numbers to the plots in numerical sequence of survey to ensure positive identification of each plot within any Mosaic Sheet.
 - 1.4.3 Measurement of the area of each plot from the Plot Boundary Maps, and recording the areas on the Farm Plot Registration Cards.

2 INSTRUCTIONS TO SURVEYORS

2.1 General

- 2.1.1 Surveyors work under the direction of the Field Supervisor and are responsible to him for all technical aspects of their work. Advice and training will be given by the Cadastre Survey Specialist during the initial two months of the project.
- 2.1.2 Surveyors must bear in mind that their work concerns the property and livelihood of large numbers of people. Care must be taken to produce a true and accurate survey in a fully professional and responsible manner.
- 2.1.3 Surveyors are expected to maintain correct, and preferably friendly, relations with the farmers, family heads, village chiefs, and all local authorities with whom they have dealings. However, any discussions on the disputed occupancy of land, numbers of trees etc are to be avoided. The Field Supervisor is to be informed of such matters, and Surveyors should concentrate on the technical side of the work. In case of dispute, or lack of representation of the farmers, which cannot be dealt with by the Surveyor/enumerator on the spot, and which prevents the satisfactory continuation of the survey, the Surveyor must immediately report back to the Field Supervisor for further guidance. Questions concerning the Ministry of Agriculture policy on Land Matters or future irrigation operation must be referred to the Field Supervisor.
- 2.1.4 Each Surveyor is expected to devote some part of his time to the training of members of his team. Chairmen and other supporting staff should be encouraged to understand the purpose and methods of the Survey, to measuring distances, search for ground features, and so on. The Surveyor should not place too much reliance on their assistant, since difficulties will arise in case of sickness or leave of absence.
- 2.1.5 Each Surveyor is responsible for general discipline of his team. Any behaviour adversely affecting the progress of the work must be reported to the Field Supervisor.
- 2.1.6 Each Surveyor should remember that the results of their field work are passed on to others to complete the final product of the survey. Every care must be taken to avoid confusion and ensure clarity in both drawing and writing.

2.2 Survey Procedures

- 2.2.1 The basis of the Field Survey is the establishment of the location of farm-plot boundaries in relation to recognisable features of ground detail by measurement where necessary, and the plotting of those boundaries on the Mosaic sheets by identification of the corresponding points of photo-detail. The Surveyor shall ask the plot owners preferably in the presence of the village headman's representative and neighbouring plot owners, the location the farm plot boundaries. The identification detail points, such as track junctions, hedge corners etc thus form a survey control net for locating and plotting the boundaries, which are frequently themselves identifiable as photo-features. Careful and intelligent interpretation of the Mosaics, with sufficient check-measurement, is essential in producing a reliable result.
- 2.2.2 A thorough reconnaissance of the area must be undertaken before starting any plot boundary mapping, and key points of identifiable detail must be clearly emphasised on the Mosaic sheet for future use.
- 2.2.3 The basic survey principles of 'closure' and redundancy of observations must be observed wherever possible. For example, where measurements have been made along a footpath from an identifiable junction to fix plot boundary corners, then a final check-measurement must be made from the last fixed corner to some other identifiable point, and the plotting verified by scaling the check-measurement on the Mosaic.
- 2.2.4 The scale of mapping is 1:2 000, 2 mm on the Mosaic representing 4 m on the ground. thus the limit of plotting accuracy is about 1 meter, and field measurement need be no more accurate than this. In cases where simple confirmation of identification of ground and photo-points is required this may often be done by rough measurement of ground distances and relatively coarse scaling on the Mosaic.
- 2.2.5 Where a boundary, as indicated by the plot owner and/or village headman's representative, is not visible as a ground feature it must be marked with a ranging pole, which is to be left in place until all related measurements and plotting are completed.

2.3 Field Mosaic Sheets

- 2.3.1 Mosaic Sheets are carried in the field by clipping them to the plywood boards provided. These are designed to hold a Mosaic Sheet folded in half across its width. Any other folding and refolding should be avoided as far as possible to reduce damage to the sheet.

- 2.3.2 The Surveyors name and starting date must be inserted in the top right-hand corner of the sheet (below the Sheet number) before beginning work on the sheet.
- 2.3.3 All plot boundaries are to be firmly drawn in with blue ball-point pen. Where a visible natural feature of photo-detail represents a boundary it must still be drawn over in ink to ensure completeness.
- 2.3.4 Any cancellation of lines must be done clearly by a series of small crosses ----x----x----x----: These should be done with a red ball-point pen if necessary for clarity.
- 2.3.5 The plot number is to be entered on each plot as soon as its limits are marked.
- 2.3.6 The plot number is to be made up of a prefix which is the Mosaic Sheet number and a sequential number for that particular sheet.
- 2.3.7 Any corrections must be made by crossing out and rewriting, not by overwriting.
- 2.3.8 Where the survey finishes along the project limit line rather than covering a whole sheet, then all plots of which any part lies in the Project Area must be fully surveyed. Plots which lie on the other side of the Area limit must not be surveyed. In case of doubt a plot should be included in the survey. Project Area limits will be drawn in red on the Mosaic Sheets before beginning field work, with reference to the appropriate Design Drawings, by the Cadastre Specialist or Field Supervisor.
- 2.3.9 At the edges of Mosaic Sheets Surveyors must ensure that surveyed details correspond exactly between adjoining sheets. The first Surveyor to deal with a particular edge will survey all plot boundaries up to their Sheet edge leaving the completion of divided plots to the Surveyor of the adjoining sheet. However, except in the case of very small portions of plots, the plot owners name and details of standing crops and trees will be recorded by the first Surveyor. When the second Surveyor comes to deal with a sheet edge of which the other side has already been surveyed he must transfer exactly to his own sheet the crossing points of plot boundary lines, and note carefully which plot owners name and details have previously been recorded, and which small portions of plots have been left for inclusion on his own side of the edge. Where two Surveyors work on adjoining sheets at the same time they must arrange to meet and work together to survey all plots crossing their common edge.

- 2.3.10 Where two Surveyors work at the same time on part of the same sheet, but using separate copies, they must work together to an agreed match-line to avoid any disagreement or duplication.

2.4 Plot Registration Cards

- 2.4.1 All headings and title information at the top of each Plot Registration Card must be completed by each Surveyor before the rest of the card is completed. The card should be signed by the Surveyor and the tear-off duplicate portion handed over to the plot owner, or if they are unavailable the village headmans representative or person who spoke for the plot owner.
- 2.4.2 All sections are to be completed as far as possible for each plot owner. If none, then 'none' must be written in full every time. Ditto marks are never to be used.
- 2.4.3 Plot owners and occupiers names are to be entered in Block Capitals, all other information is to be in lower-case block letters with capital initials. On no account is normal hand-writing script be used.
- 2.4.4 Details of the type of tenure are to be completed.
- 2.4.5 Standing crops - only the crops grown on the plot during the last 12 months are to be entered on the card.
- 2.4.6 Plot owners' names are to be written on the Registration Cards, after the correct spelling has been established. Abbreviations should not be used, and any corrections required are to be made by crossing out and rewriting.
- 2.4.7 All completed cards must be handed in the Field Supervisor at the end of each working day. The tear off identify cards are to be given to the plot owner or the village headman's representative for later distribution if they are not available.

2.5 Administration

- 2.5.1 Each Surveyor is responsible for the care and maintenance of the equipment and materials issued to him. He must ensure that measuring wheels, poles etc are properly handled by Chainmen, and are kept clean and serviceable. Any losses or breakages must be reported as soon as possible to the Field Supervisor.
- 2.5.2 Any vehicle allocated to the survey Team for work may be used only for that purpose.

- 2.5.3 During periods of the working day when the allocated vehicle is not required for travelling on site the driver must be instructed exactly where to stand by. If two teams are sharing a vehicle the Surveyors must agree in advance where the stand-by position will be.
- 2.5.4 Each Surveyor must check the attendance of members of his team day by day and he is also responsible for checking and initialling the overtime record sheets of the supporting staff in his team.

3 INSTRUCTIONS TO DRAUGHTSMEN

3.1 General

- 3.1.1 Draughtsmen work under the direction of the Field Supervisor and are responsible to him for all technical aspects of their work.
- 3.1.2 Draughtsmen must bear in mind that their work constitutes the final product of the Cadastre Survey and must be done to the highest standards. Care must be taken to ensure clarity, neatness, and a professional appearance in all drawn and written work.
- 3.1.3 Any questions or doubts arising during the course of the Draughtsman's use of Field Survey information must be resolved with the appropriate Surveyor or the Field Supervisor before final plotting or writing. No doubtful detail or uncertain information is to be allowed to go forward into the final product without verification or correction.

3.2 Plot Boundary Maps

- 3.2.1 The plot Boundary Maps are produced by tracing, with continuous ink lines on the pre-printed plotting sheets the outlines of farm plots as drawn by the Surveyors on the Field Mosaic Sheets. Plot Boundary Map Sheet lines and numbers are identical to those of the Mosaic sheets.
- 3.2.2 Plot Boundary Maps are to be drawn to the specified standard format and sheet size, using 0.25 mm pen for the boundary lines and 0.35 mm lettering size for the plot numbers. At sheet edges the drawn lines are to terminate exactly on the edge line.
- 3.2.3 Any doubtful or unclear lines or areas are not to be traced. They must be left blank, but marked with pencil queries, until they can be resolved by the Surveyor or Field Supervisor.
- 3.2.4 Before commencing work on a Plot Boundary Map Sheet the Draughtsmen must check whether any adjoining sheets are being, or have already been drawn. He must then ensure that all lines and plots which cross the sheet edges are correctly matched up from one sheet to the next before continuing with his own tracing. If necessary two Draughtsmen must set up their adjoining sheets on a single drawing board with edges coinciding and work together across the edge to avoid any discrepancies. In some cases it may be necessary to set up four adjoining sheets.

3.2.5 On completion of the tracing of outlines the Draughtsman letters the plot numbers given in the field. Each plot number is in two parts, a prefix number specified in advance for a particular Mosaic and a plot serial number within that sheet. The latter are allocated by the surveyor in the field in order of survey. Numbers are to be written with a stroke between the prefix part and the serial part thus:-

9/136 or 11/28, using the lettering stencil specified (0.35 mm). As far as possible all numbers must be written horizontally so as to be read from the bottom (South) side of the sheet. In narrow plots the number may be split, with the prefix and stroke above and the serial number below.

3.2.6 Great care must be taken in edge-comparison to ensure that a plot is neither numbered twice on adjoining sheets, nor left without a number at all. Edge-comparison of numbers must be done in all cases before inking of numbers, if necessary, first in soft pencil.

3.2.7 During the numbering process the Draughtsman should check that each plot is a fully closed figure and that two numbers do not exist within a single boundary line, however, complicated the shape may be.

3.2.8 Any unclaimed and hence unregistered areas are to be left un-numbered and appropriate notes inserted, horizontally where possible, using the lettering stencil specified, eg 'School Compound', village Area', 'Watercourse'.

3.2.9 On completion of all outline tracing and plot numbering the Draughtsman must ensure that all Title Block and marginal information is inserted. Any remaining pencil or other marks are to be cleaned off before passing the final Plot Boundary Map Sheet to the Plot Measurer for measurement.

3.3 Plot Area Measurement

3.3.1 Areas of farm-plots will be measured from the Plot Boundary map by Planimeter. Manufacturer's instructions, settings, and calibration constants, if any, must be strictly adhered to. A calibration check on each instrument must be made twice each day, once first thing in the morning and once after lunch break.

3.3.2 Areas are to be measured as accurately as possible with the available instrument and recorded to the nearest 0.01 hectares (eg 0.73, 1.48). All readings are to be entered on the plot calculation sheets (see Figure B1) with the headings filled in correctly and fully.

3.3.3 The mapping scale is 1:2 000. 1 cm at map scale therefore represents 20 m on the ground, and 1 sq cm represents 400 sq m or 0.04 hectares. To guarantee an accuracy of 0.01 hectares it is essential to read the planimeter to 4 figures. This requires smooth and careful operation of the instrument working on a flat and unobstructed surface.

3.3.4 Plots will be measured in numerical order, and each plot is to be measured at least twice. The procedure is as follows:-

Position the planimeter anchor to the top of the plot so that the plot will be comfortably covered by the planimeter arm without 'reaching'. Select a sharply defined start position such as a sharp plot-corner or junction and mark lightly with a soft pencil. Set the tracking point to the start position and note the planimeter reading on the plot area calculation sheet. Run the tracking point smoothly round the plot in a clock-wise direction to the start position. Read and book the planimeter reading on the calculation sheet. Shift the planimeter anchor to the bottom of the plot, select a new start position and repeat the whole process. Compare the difference between the two sets of values. If they agree within 0010 the mean difference is booked down. If they do not agree the process is repeated until two satisfactory readings are obtained.

3.3.5 Readings are to be booked on the Plot Calculation Sheets provided. On completion of the planimeter work on any Plot Boundary map the actual plot areas are to be derived by using the pocket calculator and multiplying by the appropriate factor for the instrument, the scale of 1:2 000, and the calibration setting. The area should then be booked to the nearest 0.01 hectares.

3.3.6 When all plot areas on a Plot Boundary Map have been measured and recorded on the Plot Calculation Sheets they are both to be passed to a draughtsman who has not been involved in the drawing or measurement of that sheet, for checking. The checking will comprise matching in numerical order the plot boundaries and plot numbers to check they have been correctly traced and then checking each plot area by eye to the measurement sheet, again in plot numerical order.

The two Draughtsmen and Plot Measurer must cooperate in resolving any discrepancies, and the true final result must be agreed between them. The amount and care needed in checking will depend on the number of errors discovered. The checking Draughtsmen must keep a record of these errors and if any are unresolved then the Field Supervisor should be consulted.

3.3.7 Plots which cross the edges of Plot Boundary Maps are to be measured complete by setting up the adjoining sheets with their common edge overlaid and a tracing taken of the pieces. The result must be recorded on the form relating to the Plot Boundary Map on which the plot number appears.

3.4 Plot Area Scheduling

The plot areas are to be copied from the plot calculation sheets onto the Farm Plot Registration Cards. The cards are to be kept secure in mosaic and numerical order. This will constitute the plot register.

3.5 Administration

3.5.1 Each Draughtsman or Plot Measurer is responsible for the care and maintenance of any equipment signed and issued to him. Drawing Instruments, pens etc are to be kept clean and in proper adjustment.

3.5.2 All instruments, equipment, and stocks of materials are to be stored where specified, and should be tidily put away after each day's work or when no longer in use. Draughtsmen's tables and drawing boards are to be kept clear and uncluttered.

3.5.3 Refreshments are not to be taken near the drawing area. Draughtsmen taking liquids such as tea or coffee, or handling food, must remain away from their tables, and should wash their hands before resuming work.

3.5.4 The Field supervisor is responsible for keeping up to date the map showing allocation and progress of drawing work. The names and dates of the staff used should be inserted in the appropriate spaces before starting work on a Plot Boundary Map, and later the date of completion. The daily work diary should be completed by each member of staff every day.

3.5.5 Any Mosaic Sheets, Detailed Design drawings, or other documents removed for use from the plot filing system must be replaced in their proper position as soon as they are finished with. If the Draughtsman is in doubt as to the proper location of a document he must hand it in to the Field Supervisor to deal with.

APPENDIX C

NOTE ON MAPPING REQUIREMENTS FOR ONGOING PROJECT WORK

In order to carry out the remaining 5 700 ha of cadastral survey it will be necessary to have controlled 1:2 000 air photo mosaics constructed. These should be in screen dia-positive (trade name Cronaflex) format to allow field copies to be easily made on a dyeline machine. There should be significant cost savings if this work is carried out by the same mapping contractor that will do the outstanding 1:2 000 contour mapping of the remaining project area. The same plan control can be used for both sets of work and consideration should be given to producing ortho-photos (ie controlled mosaics with contour lines superimposed on them in white) as these are a more appropriate product and could be significantly cheaper than photogrametric line maps.

For all this work it will be necessary to obtain a new set of contact prints from the original film rolls and also details of the plan control stations used. In order to produce the 0.25 m contours it may also be necessary to carry out more height control work in the field, although without details of how this work was originally done it is impossible to judge at present. If this is the case then the production of the controlled mosaics may well have to be carried out first so as not to delay the start of the remaining cadastral survey. In this case the existing 1:10 000 mapping could be used as plan control for the 1:10 000 air photography that has been rectified. Once these have been mosaiced they would then be photographically enlarged to 1:2 000.

Preliminary quotes in the UK indicated that the price of producing mosaics is in the order of \$500 per sheet, the whole project area being covered by some 40 sheets (see Figure 2.3, consideration should also be given to extending the coverage Eastwards to Gayweerow Barrage). For each sheet the following would be supplied:-

- 1 x screen diapositive (Cronaflex)
- 1 x Bromide photographic print (to allow full detail to be seen)
- 2 x good quality dyeline paper prints (black).

It is likely that the original mapping contractor for the work (GeoSurvey International, now trading as Photomap Kenya) is best placed to do this additional work as they still hold the original film rolls and details of the plan and height control already used.

APPENDIX D

LOGISTICAL REQUIREMENTS FOR THE CADASTRAL SURVEY

The average work rate for the cadastral survey of the trial area was about 10 ha per day. Approximately 5 700 ha gross remains to be covered which will require 570 team days. If the project goes ahead it is necessary to carry out the survey before the contractor moves onto the land. With four teams the work could be carried out in six months with drawing office operations being phased two months behind this. The following local staff would be required for a period of 6 months:

- 1 field supervisor
- 4 surveyors/enumerators
- 4 assistants
- 5 drivers
- 2 tracers/draughtsmen
- 2 plot measurers/clerks

The following equipment will also be needed:

- 5 x 4 wheel drive vehicles
- 4 x measuring wheels
- 2 x planimeters
- Fieldboards, scales, stationery, etc

Access will be needed to a photocopier and a dyeline machine and accommodation for the more senior staff will be required.

It is thought that the best time of year for doing the fieldwork is probably April till September as, although this is likely to be the rainy season and access will be difficult, the plot occupiers are likely to be in their fields.

With regard to supervision, it is considered necessary to have an expatriate cadastre survey specialist in the field for the first two months of the survey to set it up in a systematic manner and also for the last two months (ie 7 and 8) to supervise the data presentation. Attention would then be given to methods of data scheduling for compensation payment and land expropriation.

REFERENCES

Boston University African Studies Centre for US Aid
"Resource Tenure Issues in Somalia" January 1985.
Final Revised Version.

Bird AC "The Land Issue in Large Scale Irrigation Projects:
Some Problems From Northern Nigeria" in Adams WM and Grove AT (Eds)
"Irrigation in Tropical Africa Problems and Problem Solving".
African Studies Centre, Cambridge UK 1984.

Sir M MacDonald and Partners "Genale-Bulo Mareta Project"
Annex X Survey Data.
Map Supplement.
Cambridge, England July 1978.

Tippetts-Abbett-McCarthy-Stratton (TAMS).
Genale Irrigation Rehabilitation Project - Feasibility Study.
Annex 1 Natural and Human Resources. Chapter 3.
New York January 1987.

University of Wisconsin - Madison, Land Tenure Centre
"Land Tenure and Water Allocation in the Shalamood Region"
February 1987. Draft.