



ADRA

IN PARTNERSHIP WITH
SAACID VOLUNTARY ORGANIZATION

FINAL REPORT
WATER YARDS FOR
POTABLE WATER AND LIVESTOCK
IN
CENTRAL REGION, SOMALIA

Submitted to:

UNITED STATES AGENCY FOR INTERNATIONAL DEVELOPMENT
Washington, D.C., U.S.A

1
OFDA Grant # 968-1032-C-00-3032-00

Submitted by:

Adventist Development and Relief Agency (ADRA)

March 1994

TABLE OF CONTENTS

A.	FORWARD	1
I.	PROJECT SUMMARY	2
II.	INTRODUCTION	3
III.	PROJECT DESCRIPTION	4
IV.	PROJECT IMPLEMENTATION	5
V.	EQUIPMENT AND MATERIAL	16
VI.	PROJECT PARTICIPANTS	18
VII.	SECURITY SITUATION	19
VIII.	PROJECT TIME LINE	20
IX.	LINKAGES	21
X.	FINANCE REPORT	22

APPENDIX:

- Drilling Reports
- Contracts of Responsibility (4 English, 1 Somali)
- Pump Information Brochure
- Letter from H₂O Waste-Tec
- Letter from Wargadi village (Original & translation)
- Photo Appendix
- Maps

FOREWORD

The scarcity of water is endemic to many parts of Somalia. However, the lack of good management on the part of the previous government coupled with the subsequent civil war has heightened the need for water.

The need for water falls under two categories. There is the need for adequate water, as well as that of clean water, both for livestock and humans. ADRA has sought in the implementation of this project to meet both needs.

Amid the most adverse circumstances a joint effort was made by the project staff, by the communities and by fellow relief workers to meet the tasks at hand. The vision and anticipated outcome being to create an opportunity for improved health through the provision of clean and adequate water; to redeem time spent in the search for water and hopefully to motivate inhabitants to use redeemed time on more useful and economical labor; hence to place within reach, a better chance to live.

Undoubtedly, an impact has been made. Many villages, where water was a distant word for them, now mention it with the proximity of smiles. We have accomplished some of our goals, but the extent to which those goals have been accomplished cannot be measured now. Nine months is a relatively short time within which to ascertain the improvements in the quality of life of a people, more so when the output of the project was accomplished only at the end or near the end of the period. One thing can be said though, the presence of water in these villages is the beginning of new life in the district. The quality of that life can only be measured and ascertained over a period of time.

1.PROJECT SUMMERY

TITLE: Adale Water Project

GRANT NUMBER: 968-1032-G-00-3032-00

LOCATION: Central Somalia, Middle Shabelle Region, Adale District.

DISASTER DESCRIPTION: Lack of clean, potable water due to civil strife and the consequent deterioration of water wells and water yards.

PROJECT PURPOSE: The rehabilitation of the water wells, hand-dug wells and boreholes. The drilling of four new boreholes and the rehabilitation of the water yards in the Adale district. Providing clean drinking water to improve the health situation and encourage the return of displaced peoples.

BENEFICIARIES: About 30,000 people, men, women and children with their livestock in 9 villages. In addition there are many nomads with a large number of livestock who are benefiting from these improvements.

TIME PERIOD: Original: 6 months from April 1, 1993 to September 30, 1993.
With extension: 9 months until December 31, 1993.

BUDGET:

Original grant	US\$ 498,053
Grant after extension	US\$ 531,553

CONTACT ADDRESS:

ADRA International
12501 Old Columbia Pike,
Silver Spring MD 20904
Tel. 301-680-6380, Fax 301-680-6370

ADRA Somalia
3 Riverside Drive, P.O. Box 14756
Nairobi, Kenya
Tel. +254-2-448392, Fax +254-2-448391
Project Director: Frank Brenda

2. INTRODUCTION

2.1. BACKGROUND

Civil strife and famine has held Somalia in a vice-grip and has threatened over a million people with starvation. Hundreds of thousands have died. The violence and lawlessness caused the collapse of the economy and infrastructure in the entire country. Without government entities, basic public infrastructures such as wells, deteriorated. External support was required.

Water-borne diseases have affected great segments of the population. Some emergency feeding stations were forced to close due to the lack of water for cooking. Large numbers of people were displaced from their villages due to insufficient food and water supplies.

This water project was ADRA's answer to the United Nations 100 day program for Somalia. The UN outlined eight areas which required immediate action. One section was the urgent need for the provision of potable water.

2.2. SITUATION IN ADALE

ADRA started in September 1992, with an emergency medical care project in the Adale district, Middle Shabelle Region. To support the medical efforts it was necessary to improve the water situation in the district.

Three villages were totally without water, the other six villages had severe problems in running their pumps. Many breakdowns forced the people to walk hours and even days through the desert to neighboring villages to obtain water, and even this water was of dubious quality. All the water yards were in desolate condition and the people had no choice but to use contaminated water.

2.3. PROJECT OVERVIEW

To improve the water situation it was necessary to rehabilitate the wells and the water yards. In the Adale district there are shallow wells, deep hand-dug wells, and boreholes. All needed improvement and on four sites even a new borehole was necessary.

Clean drinking water is a basic human need and without water there is no life and no health. To improve the water situation is to improve the life of the people. Besides the health aspect, a good water supply encourages refugees to return to their villages. Sufficient water also allows residents and nomads to enlarge their livestock numbers, which is an important economical factor in this area, and to improve their diet through agriculture.

3. PROJECT DESCRIPTION

- 3.1. **GOAL:** To provide clean water for family use and a separate facility for watering livestock, at 9 major public sites in the Middle Shabelle Region of central Somalia within 6 months of funding (extended to 9 months) from April 1, until December 31, 1993.
- 3.2. **PURPOSE:** To improve the current living conditions in the target areas and encourage the return of displaced residents through the provision of a basic service.
- 3.3. **LOCATION:** The Adale District in the Middle Shabelle Region, central Somalia. (See appendix: Maps) Its major town, Adale, is 160 km north of Mogadishu on the coast. The district villages are located to the N.E. and the S.E. of Adale within a radius of about one hundred kilometers.
- 3.4. **OUTPUTS:** Drilled boreholes, deep hand-dug wells, covered shallow wells, piped distribution systems in the towns, pumps, diesel engines, hand-pumps, engine housings, windmills, galvanized water tanks, public taps, purified water, watering troughs for livestock, drainage support, and maintenance training.

4. PROJECT IMPLEMENTATION

4.1. REHABILITATION IN ADALE TOWN

4.1.1. Proposed:

To replace the old diesel pump in the main well, to set up a windmill in addition to the diesel pump, to rehabilitate the pump house and the two high-level water tanks, to repair the pipe system in the village, to construct two or three separate livestock watering areas with troughs, to equip some hand-dug wells with hand-pumps.

4.1.2. Accomplished:

ADRA has cleaned the main well and covered the top with wood in an area of 4 x 5m to avoid future contamination. The existing engine house has been repaired as have the two high-level water tanks (1.5m high and 36m³ each). The raising pipes and the ladder have been replaced. Broken cement parts have been repaired and the two tanks and the engine house received a new paint job.

A new diesel centrifugal pump and a galvanized windmill have been installed. In order to support the windmill the base concrete of the well was reinforced with cement and iron bars.

These two pump systems are necessary for a big district village to have as a backup. Because Adale is on the coast, there is sufficient wind to make a windmill reasonable. The quantity of water pumped by the windmill is quite sufficient, and is more economical than running a diesel engine.

In order to repair the pipe system in the village 120m of underground pipes have been replaced. At 8 places the pipe system was leaking and could be repaired. Two existing public distribution centers with six taps each, have been repaired and two new ones were constructed.

One hand-dug well has been cleaned and equipped with a hand-pump by ADRA. A second hand-dug well has been equipped with a hand-pump by UNICEF in cooperation with the Italian Forces. This has been done without consulting or informing ADRA, but we are delighted that others also recognize the existence of a problem here. The pump serves the community and fits well within our plan.

One livestock trough near the main well has been constructed. It is a big one 8m long and can be used

for camels as well as for goats and sheep. The surrounding area is paved and cemented to keep it as hygienic as possible.

4.1.3. Changes and Corrections:

It was proposed to construct two or three livestock troughs, but only one could be built. One reason was the limitation of the budget. The other reason is that many nomads are still using the open hand-dug wells for watering their livestock as they have always done. It seems that they are stuck in tradition and even the existing livestock trough is not used very much.

The two new public taps were not in the proposal. At the request of the community we added them when the pipe system was rehabilitated.

4.1.4. Problems faced:

When the new diesel centrifugal pump was installed it didn't create any suction. The mounting flange had been broken off during delivery. We had it repaired under guarantee, but we needed more than 3 months to send the part back to Nairobi, to get it repaired there and to bring the new part back to Adale. During this wait period, ADRA made available an alternative pump to provide the community with clean, potable water.

We had a similar time problem with the windmill which we ordered from Kijito Windmill Co., in Kenya. They needed 3 months for manufacturing and for one month it was in the airport waiting for transportation to Mogadishu. Finally, at the end of January 1994, it arrived in Adale and was assembled there.

4.1.5. Maintenance and sustainability:

ADRA has signed a contract of responsibility for the water well, with the community elders. (see appendix) A water committee has been appointed which takes care of the whole water system in Adale. The former well operator has received instruction on running and maintaining the new diesel pump and windmill. Because of the salty air it will be necessary to paint the windmill twice a year, even though it is galvanized.

4.1.6. Beneficiaries:

The population of Adale town is about 12,000 people, men, women and children plus their livestock. In addition there are various nomads with a large number of livestock participating in this water system.

4.2. THE WATER WELL AT GEEL GUB

4.2.1. Proposed:

To replace the old pump but not the engine, because the elders reported that only the pump was broken. To rehabilitate the old borehole, to repair the water tank, livestock trough and pipes.

4.2.2. Accomplished:

Because the old metal water tank was completely rusted, a new foundation with stones and cement has been constructed (1.5m high and 3m square) for a new water tank. The one existing livestock trough has been repaired and a second one, specifically for camels, has been constructed.

4.2.3. Changes and Corrections:

In addition to the specifications in the proposal, ADRA has constructed a distribution center with 6 public taps. We have also rehabilitated the old engine room.

4.2.4. Problems faced:

The main problem at this site was the old borehole. When ADRA made the survey, nobody could make any reliable statement about the condition of the borehole. After removing the old pump, it was possible to make a detailed investigation of this borehole.

In the beginning the borehole was dry and only 56m deep. The first solution was to clean the borehole and to drill deeper down to 90m. (A hand-dug well near-by is 74m deep which indicates the depth of the ground water table.) After accomplishing this we had clean water for one day at 73m. On the second day we were pumping sand which was coming in at 69m. At this place the casing is broken and fills the borehole with sand again. This caused the breakdown of the old pump and made the borehole dry.

To repair this borehole would be difficult because it is a small one with a 6" diameter. To run a 5" casing will not allow enough room to put a gravel pack around it in order to get sand free pumping. A new borehole is required, but the funds are not available at this time. ADRA will try to make funds available in order to complete this work.

In addition we also ordered a new diesel engine for this site. The old engine is not working properly. In the beginning the community required only a new pump but meanwhile a new engine and even a new borehole is necessary.

The diesel engine is still on the way to Somalia, as is the galvanized metal water tank from OXFAM. We hope to complete this site after receiving the additional funds for the borehole.

4.2.5. **Beneficiaries:**

The population of Geel Gub is about 2,000 people, men, women and children with their livestock. In addition there are various nomads with a large number of livestock using this well.

4.3. **THE WATER WELL AT BUR DAAR**

4.3.1. **Proposed:**

To drill or to dig a new well and to equip it with a pump and a diesel engine. To enlarge the existing water tank, to construct public taps, a new watering area for the livestock and an engine room.

4.3.2. **Accomplished:**

A new 120m borehole has been drilled with 6" steel casing, 10m screen and gravel packed to ensure sand-free pumping. The results after 24 hrs of test pumping were very satisfying. There is plenty of good drinking water. The static water level is at 70m and the pumping water level at 86m. By discharging 200L per minute, the water level will come up to 74m after 8 minutes recovery. The water has a slight salty taste, but the people in this area regard it as good drinking water. (For more details see the drilling report in the appendix.)

The borehole has been equipped with a shaft drive MONOLIFT pump and a 6.5hp diesel engine made by LISTER. Pump and engine are protected by an iron fence and an iron sheet roof. In addition a fuel storage room has been constructed from limestone, with an iron door and iron sheet roof.

The old concrete water tank has been repaired and enlarged with a new 10,000L metal OXFAM water tank from galvanized material. A new distribution site with six public taps has been constructed and also a new trough specifically for camels. The old livestock trough has been repaired and it all has been connected with pipes.

4.3.3. **Changes and corrections:**

In the beginning there was only a budget for digging a well at Bur Daar. Unfortunately when the proposal was approved there was no budget for well digging. We requested additional funding which was granted to us.

4.3.4. Maintenance and Sustainability:

The community has elected a water committee and has signed a contract of responsibility with ADRA. (See appendix) The well operators received training and instruction from our water engineer for running the diesel pump, keeping a logbook and charging the people to recover the cost of diesel, oil and filters.

Since the well is providing plenty of good water, a lot of people and their livestock from the surrounding area come to Bur Daar for water. Also people have moved to this village because there is water now. For Bur Daar this is a new situation and their lives have changed in many aspects. They have had no water for the past 8 years. The new well also takes a lot of pressure from the neighboring village of Ali Gudud. The people are very happy and appreciative of this new well.

4.3.5. Beneficiaries:

The population of Bur Daar is about 1,000 people, men, women and children with their livestock. In addition various nomads with a large number of livestock have started to visit this new water point.

4.4. THE WATER WELL AT ALI GUDUD

4.4.1. Proposed:

To replace the old diesel engine, to construct public taps and to cement the area around the livestock troughs.

4.4.2. Accomplished:

A distribution center with six public taps has been constructed. The livestock troughs have been repaired and the surrounding area was paved to keep it as hygienic as possible. A new 6.5hp LISTER diesel engine has been installed and is running well.

4.4.3. Changes and Correctives:

We changed the shaft driven MONOLIFT pump in order to have a compatible pump unit. The old pump was running heavily and needed a 20hp diesel engine which consumed a lot of fuel. The new engine needs only one liter fuel to pump 10,000 liters of water in one hour which is very economical.

ADRA has also constructed a new fuel storage room and a protection of iron fencing and an iron sheet roof for the diesel pump.

4.4.4. Maintenance and Sustainability

The community of Ali Gudud signed a contract of responsibility for the water well with ADRA and elected a water committee (see appendix). The well operator received instruction on the new pump and engine. In general they know how to run this well, to charge the water fee and to maintain it because this was the main well for the whole region for many years. The new pump unit is a real improvement for this site.

4.4.5. **Beneficiaries:**

The population of Ali Gudud is about 3,000 people, men, women and children with their livestock. In addition there are many nomads with a large number of livestock using this well.

4.5. **THE WATER WELL AT WARGAADHI**

4.5.1. **Proposed:**

To clean the hand-dug wells, to protect them by paving the surrounding area for further contamination prevention, and equip four of them with hand-pumps. Two troughs to be combined with the hand-pumps to water the livestock.

4.5.2. **Accomplished:**

Purchase of 4 hand-pumps and drilling of one shallow borehole of 30m depth without casing in rocky formation.

4.5.3. **Problems faced:**

The community refused to accept the hand-pumps after they realized that ADRA had equipped other district villages with diesel engines. They would only accept a motor pump and the construction of a big water yard. (See the letter of request in the appendix.) Also a windmill, which was proposed in the beginning, was rejected. They are not familiar with this technique and have no trust in this economical water pumping system.

The situation in Wargaadhi is different than in the other villages. Beside Adale town it is the only village near the ocean. They possess two areas with at least 20 hand-dug wells. All these wells are holes in rocky formation without protection against contamination. The depth is between 17m and 22m which is very suitable for operating a hand-pump. In the other villages the water table is between 75m and 120m which requires a motor pump.

The advantages of hand-pumps in Wargaadhi are: 1) Because of the low water table, pumping will be very

easy to handle even for women and children. 2) Water lifting will be much safer than it is now. Just a few months ago we received a patient in the Adale hospital who slipped into the well while attempting to draw water with a bucket. 3) The water will be protected against contamination which ensures clean drinking water. 4) There will be no costs for running or maintenance.

Unfortunately none of these reasons were accepted by the community. They want to have the same as the other villages and they like to have an excess of water. In the past Wargaadhi was the only water point in this area and if the motor pump in Ali Gudud had a breakdown there was a lot of pressure in Wargaadhi. But now there is a new pump in Ali Gudud and also a new well with motor pump in Mohammed Said which is just nearby, thus relieving the pressure on Wargaadhi.

The shallow borehole:

Instead of cleaning the hand-dug wells and deepening them for pump installation, the suggestion of our water engineer was, to drill a new borehole. This would save time and money and ensure sufficient clean water. The costs of drilling at this site are significantly less because no casing was needed and the water table is high.

When ADRA came with the drilling rig to Wargaadhi they thought that they would now get a motor pump. But this was a misunderstanding. In the budget and proposal there have always been hand-pumps only and never a diesel engine pump; and, in the beginning, the elders were satisfied with this plan.

After the drill the water was found to be quite salty. The community elders reported that some of the hand-dug wells are much sweeter. But probably the sweetness is due to the collection of rain water and not from the ground water. The elders refused to drink the water from the new borehole or to install a hand-pump there. They want a diesel pump with a water yard to water the livestock and will accept nothing else even if it means receiving nothing.

After reviewing all the facts mentioned above, ADRA decided against agreeing to their demands. Unless there is cooperation we will not be able to do anything more at this site. The purchased four hand-pumps can be used at other sites where they are more needed and welcomed if USAID agrees.

4.5.4. Beneficiaries:

The population of Wargaadhi is about 2,000 people, men, women and children with their livestock. In addition many nomads with a large number of livestock are also using the hand-dug wells.

4.6. THE WATER WELL AT MOHAMMED SAID

4.6.1. Proposed:

To rehabilitate the collapsed hand-dug well. To construct a water yard with tank, public taps and livestock troughs. To equip the well with a motor pump and to install a hand-pump at the rain water pool.

4.6.2. Accomplished:

In January 1993, before USAID funding started, ADRA had rehabilitated the hand-dug well at its own expense. This well was already dug to 50m depth but was still dry and had collapsed in the bottom because of insufficient cement casing. The cement casing has been refurbished and deepened to 65m to get the water. Unfortunately the salinity of the water was very high.

4.6.3. Changes and Corrections:

Because of the salty water and the small quantity we decided not to spend more money for a motor pump and the construction of a water yard at this site. When the geologists from the ground water survey came to the district later, the elders from Mohammed Said requested a survey of their site for sweet water. We took the opportunity and, according the geological report, there was an area outside of the village which was supposed to have sweet water. Based on this report we requested more funds for drilling a new borehole at Mohammed Said.

ADRA has drilled a 100m borehole with 8" steel casing, 10m steel screen and gravel packed to ensure sand free pumping. After 24 hours of test pumping, the water quantity was not as plentiful as Bur Daar but was adequate. By discharging 50 liters per minute the water level came down from 40m to 84m and it needed 20 minutes to recover to 47m. (For more details see the drilling report in the appendix.) The water is less salty than in the hand-dug well.

A water yard has been constructed with public taps, two livestock troughs, water tank foundation, and engine room. Unfortunately the metal water tank, the diesel engine and monolift pump have not arrived in Somalia yet, but are on the way. They will be installed as soon as they arrive.

4.6.4. Maintenance and Sustainability:

The community has elected a water committee and signed a contract of responsibility for the water well with ADRA. The two well operators received some training

during the drilling and pump testing. After pump installation they will receive more training.

4.6.5. **Beneficiaries:**

The population of Mohammed Said is about 1,000 people, men, women and children with their livestock. In addition there are various nomads with a large number of livestock who will also use this well.

4.7. THE WATER WELL AT HAGI ALI

4.7.1. **Proposed:**

To change the pump and diesel engine, to repair the 2 livestock troughs, the pipe system, the engine house and the water tank; to construct a distribution center with public taps.

4.7.2. **Accomplished:**

The rehabilitation of the water yard was completed successfully. 60m of broken and leaking pipes have been replaced. The leaking concrete water tank has been repaired, covered and newly cemented. The engine room got a new iron sheet roof, and an iron window and door. The walls have been repaired and newly painted. The area around the two livestock troughs has been cemented to keep it as hygienic as possible. A new distribution center with six public taps has been constructed.

4.7.3. **Problems faced:**

Hagi Ali has two wells, one deep hand-dug well of about 70m depth and one borehole well running with an old diesel engine. In the very beginning a windmill was suggested for the hand-dug well in order to pump free water without costs for diesel. After discussion with the community elders they requested a new diesel pump and were willing to pay for the diesel. The old engine and pump had several breakdowns and ADRA agreed to this solution.

When we wanted to install the new pump unit, the elders and well technicians refused the replacement. The new pump and engine looked much smaller than the old one they are running now. Their concern is that the small new pump can't provide enough water.

It was not possible to convince the elders and technicians that the new pump is more efficient and more economical than the old one. Pumping 10,000 liters per hour is really sufficient for this place and their old pump which is the same MONOLIFT type doesn't provide more water. The old type is only bigger and heavier in design and equipped with a 20hp

engine which needs much more fuel.

In the present situation we can't do more than we have done in the rehabilitation of the water yard. We respect the decision of the community regarding the pump and ask USAID if we can use this pump for another site in one of our next water projects.

4.7.4. **Beneficiaries:**

The population of Hagi Ali is about 3,000 people, men, women and children with their livestock. In addition there are various nomads with a large number of livestock using these this well.

4.8. THE WATER WELL AT ADDOW UL

4.8.1. **Proposed:**

To replace the old pump and engine, to rehabilitate the two livestock troughs, the water tank, the engine room, the pipes and to construct a new distribution center with public taps.

4.8.2. **Accomplished:**

The water yard has been rehabilitated. The area around the two livestock troughs has been cemented to keep it as hygienic as possible. The small concrete water tank has been repaired and a foundation for a second metal OXFAM water tank has been prepared. The capacity of a second water tank is needed because of the large number of livestock in this area. The water tank is still on the way to Somalia and will be installed immediately after arrival.

A distribution center with six public taps has been constructed. Leaking pipes have been changed and the engine room has been rehabilitated.

4.8.3. **Changes and Corrections:**

In the beginning, Addow Ul was not part of the Adale Water Project. Because of some security problems in the Nur Dugele district and the lack of cooperation we couldn't take any action there. After informing USAID, we changed the location and their budget to Addow Ul which belongs also to the Adale district.

4.8.4. **Problems faced:**

In the beginning the community elders requested only a new pump. Some months later they had severe problems with the engine and asked ADRA for a replacement. We ordered one immediately, but the shipment has not arrived yet.

During the time of waiting the community technicians tried to repair the pump by themselves without consulting or informing ADRA. When they took out the pump, some pieces of the column pipe fell down into the borehole. They were not able to retrieve them. Now our engineers have to try. We will move with our drilling rig and equipment to this site as soon as the shipment with the ordered material arrives. Then we can kill the proverbial two birds with one stone.

4.8.5. Beneficiaries:

The population of Addow U1 is about 3,000 people, men, women and children with their livestock. In addition there are many nomads with a large number of livestock using this well.

4.9. THE WATER WELL AT RAGE ELLE

4.9.1. Proposed:

A complete new water well with a new borehole, diesel pump and water yard with livestock troughs, public taps, water tank and engine room.

4.9.2. Accomplished:

A new 125m borehole has been drilled with 8" plastic casing. According the recommendations of the ground water survey geologists the borehole has been sealed. The reason is a salt water level on top and a sweet water level further down. After sealing at 102m we found a big sweet water reservoir at 125m. The results after 24 hours test pumping were very satisfying. By discharging 240 liters per minute the water level came down from 23m to 26m. (For more details see the drilling report in the appendix.)

Two new livestock troughs have been constructed with a cemented surrounding area. The old concrete water tank was rehabilitated. A new distribution center with six public taps and a new engine room have been constructed.

4.9.3. Problems faced:

After receiving sweet water in the beginning the taste became salty. The borehole was drilled to 125m and the 8" casing for sealing was run until 102m. When we wanted to continue with a 6" casing we could run it only until 82m. It appears that the hydrostatic pressure in the hole caused the plastic casing to collapse. There is still enough water in the borehole, but it is salty.

Deeqa Construction Co. to whom we have contracted the drilling, has promised to consult some more experts

about this problem. If the borehole can't be repaired they will drill a new one at their own expense.

4.9.4. Beneficiaries:

The population of Rage Elle is about 3,000 people, men, women and children with their livestock. In addition there are various nomads with a large number of livestock using this well.

5. EQUIPMENT AND MATERIAL

5.1. The drilling rig.

It is a DEEP ROCK Model 155 and has been purchased new from the USA by Deqa Construction Co., in order to fulfill this water project. We have had a bad experience with hiring an old local rig. We did this for one well funded by the Canadian High Commission. But during the process of drilling this old rig had two breakdowns and it needed weeks for repairs. It was not feasible to continue with that rig for the Adale water project.

Some specifications for the new drilling rig we used: It has a rotary drill and is equipped with a 470 cubic feet per minute (cfm) air compressor at 200psi. It has a 3 x 4 centrifugal mud pump with a capacity of 300 gallons per minute (gpm). At 150psi it has a 9gpm John Bean water injection pump for air mist, air, water or foam drilling.

The drill uses 4.5" drill pipe and is capable of pulling back 15,000 pounds or approximately 700ft of drilling pipe. It is also equipped with a down hole air hammer for hard rock drilling with air - air plus additives.

The drilling machine is powered by a cat diesel engine and mounted on a 1993 - F 700 series Ford truck, 4 wheel drive with Cummings power.

5.2. The pumps and diesel engines

All the pumps used in this project are shaft driven MONOLIFT pumps from H₂O WASTE TEC, made in UK. The reason for using this type is the long sustainability and the very economical operation.

The pumping principle is a very simple one. A hard chrome-plated rotor lays inside in a rubber stator and screws the water up to the surface. This type has been used often in Somalia and even after 20 years these pumps are still running. The new models have been refined and a longer life can be expected. (For more details look at the brochure in the appendix).

As opposed to submersible pumps these pumps are not adversely affected by sand pumping or dry pumping. Also repairs are much easier to the MONOLIFT pump than repairs to a submersible pump. Most Somalis are familiar with this type of pump which ensures sustainability.

This new type of MONOLIFT pump requires only a small 6.5hp diesel engine to run. The diesel consumption is only one liter per hour, and in this time 10,000 liters of water can be pumped which is very economical. The engines we used are all made by LISTER which is the most common type found in Somalia. Spare parts are easily available also in Somalia.

5.3. Construction of engine room and pump shelter

The engine room is a limestone building 4 x 3m plastered and painted white. It has one iron door and one iron window. Both can be locked. The roof is wood framed covered with iron sheets. Usually it is used as a storage room for fuel and spare parts. Also the well operator stays there when he is on duty.

In order to protect the pump and engine unit, an iron fence 3 x 3m has been constructed around it. There is one door which can be locked. The roof is wood framed covered with iron sheets. This construction allows for free access to the pump, engine or borehole if repairs with a crane or a drilling rig are necessary. At the same way it protects the pump unit from children, thieves and animals.

5.4. Construction of livestock troughs:

The troughs are all made with concrete which is very solid and long living. They are 3m long and have a cemented surrounding area of 2m to keep the area as hygienic as possible. There are two types of troughs. A low one for goats, sheep and cattle, and a higher one for camels.

5.5. Construction of public taps

It is a solid concrete construction and each unit is equipped with 6 taps. The tap model is from UNICEF which has been specially created for public use. Our experience with ordinary taps has been very poor.

5.6. Construction of water tanks

The type we used in this project is the 10,000 liter water tank from OXFAM. It is a metal water tank, galvanized and inside equipped with plastic foil. The tank is covered and protected against contamination.

To use the full capacity of the tank we have constructed a foundation of rocks and cement, 1.5m

high and 3m square.

6. PROJECT PARTICIPANTS

6.1. GROUND WATER SURVEY LTD.

In order to prepare the borehole drilling we have contracted the services of the GROUND WATER SURVEY CO. in Nairobi, Kenya. The hydro-geologist who came to Somalia was Mr. Karanja. He has visited the sites in Bur Daar, Mohammed Said and Rage Elle.

The purpose was to investigate the condition of the underground formations and to locate the best places for a new borehole. In the survey the resistivity method (also known as the geo-electrical method) has been used. Vertical electrical soundings (VES) were attempted, to probe the condition of the sub-surface layers and to confirm the existence of deep ground water. The results were presented in a comprehensive report which was a good guidebook for the driller.

6.2. DEQA CONSTRUCTION CO.

Most of the work has been contracted to the Somalian DEQA CONSTRUCTION COMPANY, based in Mogadishu. The director is Abdulkadir Mohammed Nur. With his team he has constructed the water yards, installed the pipes, pumps and engines. He also bought a new drilling rig from USA in order to fulfill our well drilling requirements.

Mr. Nur, his engineer Maow, and his foreman Osman Subcane have done very good work under difficult circumstances. They faced a lot of problems in getting the proper material and equipment in a country without any infrastructure. They also had to handle some security problems in Mogadishu. Nevertheless they have shown that they can accomplish this work in a timely and efficient manner with proper attention paid to quality.

6.3. SAACID

The local NGO, SAACID, became our partner in of ADRA's projects in Somalia. The director is Mrs. Khadija Ossoble Ali. Her assistance and influence has been of great value. Through SAACID we got all the logistic support to run our office in Mogadishu, to have storage space, vehicles and security. They have been of inestimable value in our dealings with the community elders when problems arose. ADRA has appreciated this partnership very much and we will continue with it.

ADRA STAFF MEMBERS

The following list mentions all those who were involved in the Adale Water Project. Some of them were staying for long term, others served only a short period.

NAME	NATIONALITY	TITLE
Haraldo Seidl	Brazilian	Exec. Director
Rita Grusebeck	American	Administr. Asst.
Richard Hall	American	Country Director
Wes Mc Donald	American	Acting Director
Ronald Kuhn	Brazilian	Acting Director
Fred Kumah	Ghanaian	Acting Director
Frank Brenda	German	Project Director
George Garcia	Argentinean	Water engineer
Andrew Kimani	Kenyan	Water engineer
Dave Robertson	Canadian	Driller

For the office in Nairobi:

Mike Odera	Kenyan	Accountant
Hosea Arewi	Kenyan	Asst. Accountant
Willykister Arunga	Kenyan	Office Manager
Lillian Sayi	Tanzanian	Logistics Officer

For the office in Mogadishu:

Osman Sheik	Somali	Logistics Asst.
Abdel Rahman	Somali	Office Manager

7. SECURITY SITUATION

In general the Adale district can be considered a safe area. There have been no clan clashes or conflicts between groups. Even during the civil war it was a quiet region.

The community elders were usually cooperative and supportive of ADRA in the implementation of the projects. Problems raised could be always solved in a peaceful way. The people in the district appreciate the work of ADRA and are very thankful, since ADRA is the only international NGO in this district.

The problem of bandits is one that the whole country of Somalia is facing, the Adale district being no exception. We had several incidents on the way between Mogadishu and Adale. There were attempts of car-jacking, but we were always able defend ourselves.

The biggest security problem was in Mogadishu. From the logistic aspect we always had to go through Mogadishu for supplies and travel. This was sometimes very difficult or

even impossible.

After the killing of 12 Pakistani UN soldiers on June 5th we were evacuated by the UN for nearly two months. The project couldn't continue during this time. After we returned to Somalia the logistic pipeline for all our material from Nairobi or Mombassa through Mogadishu was often blocked.

8. PROJECT TIME LINE

8.1. General:

The project started at April 1, 1993, and was scheduled for completion in six months, September 30, 1993. During the time of evacuation we asked for extension until December 31, 1993. We scheduled our work in this way so we could complete the project in December.

Unfortunately there were some factors beyond our control that have prevented us from completing this project as expected.

8.2. Reasons for the delay:

- 8.2.1. The arrival of the new drilling rig coming from USA was scheduled for July. But a delay in manufacturing and shipping delayed arrival in Mogadishu 'til the 21st of November.
- 8.2.2. The windmill was ordered in September from KIJITO in Kenya. It took 3 months for manufacturing and was then delayed for 6 weeks at the Kenyatta airport while awaiting transportation to Mogadishu. It arrived on January 18, 1994. The windmill is now assembled and operational in Adale.
- 8.2.3. In the beginning of the project we ordered the proposed number of pumps and engines. Later after some changes were made (as reported above), more pumps and engines were required. This order has been made to H₂O WASTE TEC in UK on October 29 and November 2. The delivery was scheduled for December 10. After several delays from their side the shipment should arrive on February 21 in Mombassa. (See letter from H₂O WASTE TEC in the appendix.) But unfortunately the vessel had one week more delay and will arrive on February 27. After arriving in Mombassa it also needs some time for overland transport to Mogadishu. For this reason several pumps and engines have not yet been installed.
- 8.2.4. In the beginning we got some water tanks from OXFAM in Mogadishu directly. Since we requested more they asked us to order them ourselves directly from the United Kingdom. These water tanks we put in the same

container shipment as the pumps and engines. They will arrive together.

3.3. Conclusion:

All these delays are beyond our control. That which we could do, we have done. As soon as the shipment arrives in Mogadishu, we will install the pumps, engines and water tanks at ADRA's own expense. We will inform USAID when the work has been completed.

9. LINKAGES

9.1. WITH OTHER PROJECTS

The Adale Water Project is part of a community project for the Adale district. Parallel to this project ADRA has conducted a health program for the whole district. With funds from OFDA/USAID it is running a hospital in Adale with inpatient and outpatient departments, with a surgical theater, a laboratory and a pharmacy. It has set up a vaccination program with cold chain and a tuberculosis program.

Beside the Adale hospital, ADRA has established in each district village a health post. All eight health posts were visited on a regular basis by community health workers, giving training to the health post workers and support them with medicine. Also a mobile clinic transfers patients to the hospital. (For more detailed information see the final report, Emergency Medical Care.)

The important goal for both projects was to improve the health situation. Many diseases are transferred by polluted water. Because of the lack of clean drinking water, people had no other choice than to drink contaminated water. Through this project the water situation was improved significantly. Also the number of water-born diseases were reduced as mentioned in the hospital report.

9.2. WITH OTHER AGENCIES

ADRA is a member of the NGO consortium in Mogadishu. Through the consortium regular water meetings have been organized. These water meetings are helpful in sharing experiences with other NGOs working in the water section. We tried to standardize a certain type of pumps and engines in order to make it easier for the Somalis to get spare parts later on.

We also used the service of the German THW (Technisches Hilfs Werk). They had a laboratory for water analysis. We gave them water samples from the Adale district. Unfortunately they couldn't continue with their work, since they left Mogadishu for security reasons.

FINAL REPORT

FINANCIAL STATEMENTS

USAID / OFDA 968-1032-G-00-3032-00

Submitted to

USAID / OFDA OFFICE

BY

ADRA SOMALIA PROJECTS

The following represents the final financial statements for the OFDA Water project.
 The first page has additional details to be found in the attachments, Page 1a, Page 1b, and Page 1c.
 The following pages are notes to the statement.

EXPENSE REPORT FOR THE PERIOD MARCH - DECEMBER, 1993

	ACTUAL	BUDGET	Variance
PERSONNEL	\$52,344.81	\$48,300.00	(\$4,044.81)
TRAVEL & PER DIEM	\$5,078.21	\$3,040.00	(\$3,038.21)
TRANSPORTATION	\$17,387.85	\$38,100.00	\$20,712.14
EQUIP. & SUPPLIES	\$366,226.20	\$340,700.00	(\$25,526.20)
OTHER DIRECT COSTS	\$4,162.82	\$11,600.00	\$7,437.18
INDIRECT COSTS	\$89,813.00	\$89,813.00	\$0.00
TOTALS	\$536,012.90	\$531,553.00	(\$4,459.90)

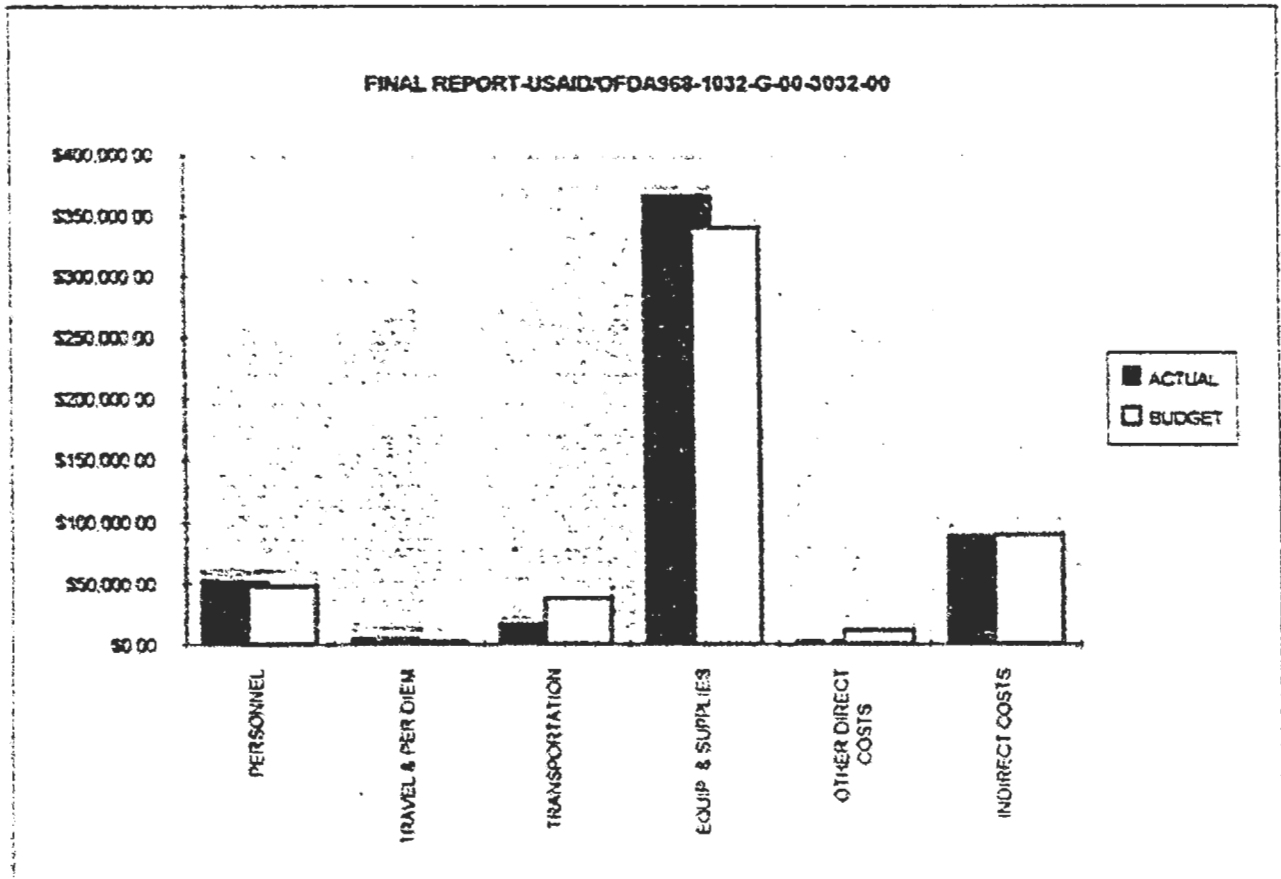

23

FINAL REPORT

NOTES TO THE FINANCIAL REPORT

OFDA968-1032-G-00-3032-00

As a background to the reason for the variances, we think it is important to mention points that were raised at a USAID / OFDA workshop held in Nairobi and discussions with project officers of USAID / OFDA. It was made clear at the OFDA workshop that with the OFDA grants of Somalia, of which this is a part, there isn't any limitation on movements within budget line items, as well as within broad budget categories, provided one stays within the overall budget specifications and keeps the USAID / OFDA representatives informed. There has been variances within our broad budget categories, due to the circumstances that prevailed in Somalia during the course of the project. We did, as much as was possible, inform the USAID project officers responsible, and they gave us verbal approvals to continue as was possible.

PERSONNEL: The actual expenditure was slightly over the estimated budgeted amount. The costs of employing expert expatriate assistance was a bit higher than anticipated. However, the variance wasn't that significant as shown by the figures.

TRAVEL

& PER DIEM: The actual expenditure exceeded budgeted figures because of two reasons:

- a. Due to the volatile and unsecure environment of Somalia, it was difficult to find contract workers that were willing to devote 9 months to the project. Even if they did initially, the unsecure environment led to their termination of their contracts. Hence we had a frequent turnover in our expat staff, which meant more in terms of International travel costs to us. Increased movement led to higher than anticipated costs.
- b. Per diem was also high because of the need for frequent movement. On two occasions, on the advice of UNISOM and the US embassy, we had to evacuate our staff from the project site due to unrest in Mogadishu which posed potential security problems to our staff. They stayed in total for over five weeks. This meant increased cost in Hotels and food, and hence Per diem allowances. These were circumstances beyond our control which the local USAID office is well aware of.

TRANSPORTATION:

The actual expenditure in this case was less than estimated budgeted amount. This is mainly because, our contractor for the job, built into most of his charges the costs of transportation. Hence, we ended up spending less directly to this line item. Indirectly however, we have spent that much but mostly combined with the equipment and supplies charges.

EQUIPMENT &

SUPPLIES: The costs involved was higher than we had budgeted for. Generators were not utilized to power engines, since we utilized Monolift pumps, which has a combined unit, the generator within the pump. The other variance which was significant is the borehole drilling costs. With hardly any drilling rigs in Somalia, the costs of drilling is rather high, due to lack of competition. The high risks factor involved in operating a drilling rig in Somalia where there is no insurance coverage, also contributed to the high costs of drilling.

OTHER DIRECT

COSTS: Actual expenditure was less than estimated budgeted amount. This is mainly because, an evaluation of the project and audit of the books are yet to be done.

INDIRECT: As allocated to ADRA International.

Title of Property
OFDA 968-1032-G- 00- 3032-00

The following represent assets purchased during the life of the above project that were below \$2,000.00 but above \$500.00. Per USAID regulations, title of assets below \$2,000.00 reverts to participating agency at the end of the project.

<u>Qty</u>	<u>Description</u>	<u>Costs</u>	<u>Ref.</u>	<u>Location</u>
1	FT-890 YAESU Transceiver	\$1,867.17	CK. 1042	Mogadishu
*4	Hand Pumps @ \$998.86 each	\$3,995.44	CK.034035	Mogadishu
*1	Diesel Engine	\$5,114.09	CK. 034034	Mogadishu

Disposition of Capital Assets

The property of the first item, FT - 890 YAESU Transceiver, per USAID regulation, reverts to ADRA because it is below the \$2,000.00 limit.

* The Hand Pumps and Diesel Engine are not capital assets per the budget. They are part of materials for the project which should have been expended. However, as explained in the final report, the villages concerned refused the pumps and the diesel engine for reasons stated earlier. We propose to use these Hand Pumps and Diesel Engine in other villages where the need is great and will welcome the equipments. Your approval of this proposition will highly be appreciated.

ATTACHMENTS TO FINANCIAL REPORT

1. Page 1 a - Balance Sheet
2. Page 1 b - Income Statement
3. Page 1c - Income Statement Coatl.

02/04/1994
02:17:50

B-MIDDLE SHABELLE WATER PROJECT
ADRA SOMALIA
USAID/OFDA 968-1032-G-00-3032-00
BALANCE SHEET
JANUARY 31, 1994

PAGE 1
USD = 1.0000
CURRENCY : USD

	USD	USD
ASSETS		

CURRENT ASSETS		

BANK LOCAL	0.00	0.00
BANK -CITIBANK NY	0.00	0.00
A/R ADMINISTRATION	0.00	0.00

TOTAL CURRENT ASSETS	0.00	0.00
=====		
LIABILITIES		

CURRENT LIABILITIES		

A/P ADMINISTRATION	4,459.90	4,460.00

FUND BALANCE		

FUND BALANCE		

FUND BALANCE	-4,459.90	-4,460.00

TOTAL LIABILITIES AND FUND BALANCE	0.00	0.00
=====		

02/04/1994
02:18:05

B-MIDDLE SHABELLE WATER PROJECT
ADRA SOMALIA
USAID/OFDA 958-1032-G-00-3032-00
STATEMENT OF INCOME AND EXPENSES
FOR 10 MONTHS/12 ENDED JANUARY 31, 1994

PAGE 1

USD = 1.0000
CURRENCY : USD

	CURRENT MONTH	YEAR TO DATE	TOTAL BUDGET
INCOME			

INCOME			

ADRA CONTRIBUTION	0.00	0.00	0.00
USAID/OFDA - 3032	0.00	441,740.00	441,740.00
TOTAL INCOME	0.00	441,740.00	441,740.00

EXPENSE			

PERSONNEL			

PROJECT DIRECTOR	0.00	33,438.00	24,000.00
ASST. PROJECT DIRECTOR	5,000.00	7,119.75	3,000.00
ACCOUNTANT	0.00	3,349.98	5,100.00
CASUAL LABOR	0.00	8,317.08	5,400.00
SECURITY GUARDS	0.00	120.00	10,800.00
TOTAL PERSONNEL	5,000.00	52,344.81	48,300.00

TRAVEL AND PER DIEM			

AIRFARE	0.00	1,327.50	700.00
LODGING	413.05	2,742.47	1,500.00
TAXI FARES	0.00	867.28	300.00
PER DIEM	0.00	1,120.96	540.00
TOTAL TRAVEL AND PER DIEM	413.05	6,078.21	3,040.00

TRANSPORTATION			

VEHICLE RENTAL	0.00	13,507.19	18,000.00
TRANSPORTATION/FRIEGHT	0.00	3,880.67	20,100.00
TOTAL TRANSPORTATION	0.00	17,387.86	38,100.00

EQUIPMENT AND SUPPLIES			

GENERATORS (4)	0.00	0.00	40,000.00
DIESEL ENGINES (2)	0.00	51,352.79	14,000.00
WINDMILL (3)	0.00	9,257.42	36,000.00
SUBMERSIBLE PUMPS	0.00	16,969.40	17,500.00
HANDPUMPS (11)	0.00	12,225.62	5,500.00
WATERING TROUGHS	0.00	56,535.65	42,000.00
RESERVOIR TANKS (7)	0.00	2,416.20	24,000.00
PIPES	0.00	42,883.48	35,000.00

02/04/1994
02:18:06

B-MIDDLE SHABELLE WATER PROJECT
ADRA SOMALIA
-USAID/OFDA 968-1032-G-00-3032-00
STATEMENT OF INCOME AND EXPENSES
FOR 10 MONTHS/12 ENDED JANUARY 31, 1994

PAGE 2

USD = 1.0000
CURRENCY : USD

EXPENSE	CURRENT MONTH	YEAR TO DATE	TOTAL BUDGET
EQUIPMENT AND SUPPLIES			
SAND/GRAVEL/STONE/CEMENT	0.00	28,257.95	21,500.00
TOOLS & EQUIPMENT	0.00	3,730.30	1,000.00
TESTING KIT	0.00	0.00	500.00
WATER PURIFYING CHEMICAL	0.00	0.00	900.00
HAND RADIOS (3)	0.00	3,349.67	3,200.00
GENERATOR	0.00	5,400.00	6,000.00
BOREHOLE DRILLING	0.00	133,500.00	90,000.00
PUMP INSTALLATION	0.00	345.70	3,600.00
TOTAL EQUIPMENT AND SUPPL	0.00	366,226.20	340,700.00
OTHER DIRECT COSTS			
OFFICE/HOUSING & STORAGE	0.00	2,625.00	6,000.00
OFFICE SUPPLIES	15.00	1,477.66	600.00
EVALUATION	0.00	40.16	3,000.00
AUDIT	0.00	0.00	2,000.00
TOTAL OTHER DIRECT COSTS	15.00	4,162.82	11,600.00
TOTAL EXPENSE	5,428.05	446,199.90	441,740.00
INCREASE/DECREASE	-5,428.05	-4,459.90	0.00

Appendix

DRILLING REPORTS



Borehole No. _____
Borehole Name BUR DAR
Formation _____

To be filled in TRIPPLICATE

1. Location: BUR DAR _____ ADALE District.
Map Sheet: _____ Scale: _____ Coordinates: _____ N/S
Area: _____ E

(See sketch page 4) Elevation: _____ m. above msl.
2. Owner: BUR DAR COMMUNITY; Address: _____

Locality/Estate: _____; L.R. No.: _____
Intended Use:—Public W.S.; Irrig.; Indust.; Domestic; Stock; Other: DOMESTIC

3. Contractor: _____; Address: _____
Licence No.: _____; Gazetted on _____; Drilling Supervisor: _____
(Date)

4. Type of Borehole:—Drilled; Driven; Bored; Jetted; Other: DRILLED
Type and Make of Drill Rig: ROTARY

5. Borehole Construction (also see sketch page 3)
Drilling started: 5-12-93; Drilling completed 8-22-93; All work completed _____
(Date) (Date) (Date)

Total Depth: Reported 120 m.; Measured 120 m.; Final (back-filled) Depth: _____ m.
Hole Diameter: _____ mm. from _____ m. to _____ m.
_____ mm. from _____ m. to _____ m.
_____ mm. from _____ m. to _____ m.

Permanent Casing:

Plain:
Type STEEL; Diam. 203 mm.; Length 335 m., from 0 m. to 110 m.
Type _____; Diam. _____ mm.; Length _____ m., from _____ m. to _____ m.

Slotted or Perforated:

Size and Description of Openings _____;
Type _____; Diam. _____ mm.; Length _____ m., from _____ m. to _____ m.

Screen:

Type and Make STEEL _____;
Diameter 203 mm., Length 4.6 m., set from 110 m. to 120 m.

Gravel Pack:

Size of grains 4 mm., Roundness (good, fair, poor), Volume inserted in to annular space _____ cu. m., from _____ m. to _____ m.

Open Hole: Diameter _____ mm., from _____ m. to _____ m.

6. Aquifer: 1st Water Struck at _____ m.; Water rest level _____ m.
Main Aquifer Struck at 40 m.; Water rest level 70 m.

Water-bearing material: GRAVEL, from _____ m. to _____ m.

Other Aquifers, Remarks, etc.:

(also see log on page 3)

7. Yield: SWL 70 m.; PWL 86 m. below surface; Discharge 200 lpm, after pumping 2 1/2 hours; Recovered to SWL in 8 minutes; Recommended production discharge 10000 lph., with pump set at 190 m. below surface.
8. Pumping Test Record in Summary (Detailed test records on attached sheets): (all depth measurements to be in metres below ground surface).

Date of Test (day, month, year) 12-12-93

Depth of Borehole at time of test

Water Entry (perforations or screen setting at time of test)

Static Water Level (SWL) before test

Type of Pump (or Bailer) used 2-1/2" DIAPHRAGMATIC

Depth of Pump Intake

Discharge (in litres per minute)

Pumping Water Level (PWL)

After pumping continuously for

Time of Recovery to Original SWL

Rate of Recovery—WL after 5 minutes

20 minutes

60 minutes

180 minutes

Test No. 1		Test No. 2	
120 metres		metres	
from m.	to m.	from m.	to m.
70 metres		metres	
2-1/2" DIAPHRAGMATIC			
metres		metres	
200 lpm.		lpm.	
86 metres		metres	
2 1/2 hours		hours	
8 minutes		minutes	
72 metres		metres	
metres		metres	
metres		metres	
metres		metres	

(Additional pumping tests to be mentioned in REMARKS and included with file).

Government representative witnessing the test

9. Quality of Water: Sample Yes, Collected at _____ hour on _____ (Date)
 No

Sediment _____, Taste Salty, Odour _____

Colour _____; Temperature _____ °C.; Spec. Conductivity _____ umho/cm³

10. Remarks: (drilling difficulties, gravel-pack details, all pertinent information about the drilling and completion of the hole);

(Signed)

Drilling Supervisor

(Signed)

Drilling Contractor

Borehole No. _____

11. Driller's Log:

12. Sketch of Borehole Construction:

From (m.)	To (m.)	Drilling rate (m./hr.)	Description of formation penetrated
0	2		Top sand
2	40		Lime stone
40	80		Sand stone
80	120		Sand

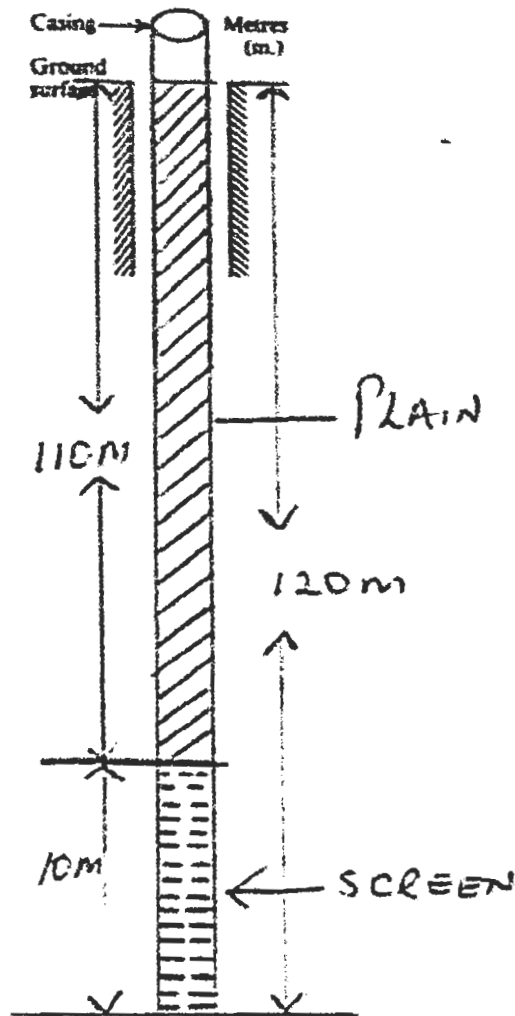

(Geologist's log on attached sheets).

Remarks or additional information on Driller's log, or on sketch of borehole:

Total depth

(Sketch to include:—depth and changes of hole diameter; casing positions, manner of casing (of different diam.) connections, and casing connection to screen; depths of screens or slotted casing lengths; how casing is closed at bottom; formation caving zones; and any other pertinent information).



7/2/93

Borehole No. _____
Borehole Name MOHAMED SAID
Formation _____

To be filled in TRIPLICATE

1. Location: MOHAMED SAID ADALE District.
Map Sheet: _____, Scale: _____, Coordinates: _____ N/S
Area: _____ E

(See sketch page 4) Elevation: _____ m. above msl.

2. Owner: COMMUNITY; Address: _____

Locality/Estate: MOHAMED SAID; L.R. No.: _____
Intended Use—Public W.S.; Irrig.; Indust.; Domestic; Stock; Other: DOMESTIC

3. Contractor: _____; Address: _____
Licence No.: _____; Gazetted on _____; Drilling Supervisor: _____
(Date)

4. Type of Borehole—Drilled; Driven; Bored; Jetted; Other: DRILLED
Type and Make of Drill Rig: ROTARY

5. Borehole Construction (also see sketch page 3)
Drilling started: 12/12/93 (Date) Drilling completed: 14/12/93 (Date) All work completed: 20/12/93 (Date)

Total Depth: Reported 100 m.; Measured 100 m.; Final (back-filled) Depth: _____ m.
Hole Diameter: _____ mm. from _____ m. to _____ m.
_____ mm. from _____ m. to _____ m.
_____ mm. from _____ m. to _____ m.

Permanent Casing:

Plain:
Type STEEL; Diam. 203 mm.; Length 5.35 m., from 0 m. to 90.3 m.
Type _____; Diam. _____ mm.; Length _____ m., from _____ m. to _____ m.

Slotted or Perforated:

Size and Description of Openings _____;
Type _____; Diam. _____ mm.; Length _____ m., from _____ m. to _____ m.

Screen:

Type and Make STEEL _____;
Diameter 203 mm., Length 0.6 m., set from 90.3 m. to 100 m.

Gravel Pack:

Size of grains 4 mm., Roundness (good, fair, poor), Volume inserted in to annular space _____ cu. m., from _____ m. to _____ m.

Open Hole: Diameter _____ mm., from _____ m. to _____ m.

6. Aquifer: 1st Water Struck at 45 m.; Water rest level 40 m.
Main Aquifer Struck at _____ m.; Water rest level _____ m.

Water-bearing material: Gravel, from 45 m. to _____ m.

Other Aquifers, Remarks, etc.:

(also see log on page 7)

7. Yield: SWL 40 m.; PWL 84 m. below surface; Discharge 50 lpm, after pumping _____ hours; Recovered to SWL in 30 minutes; Recommended production discharge 3000 lpm, with pump set at 90 m. below surface.
8. Pumping Test Record in Summary (Detailed test records on attached sheets): (all depth measurements to be in metres below ground surface).

Date of Test (day, month, year) .. 20/12/93

Depth of Borehole at time of test

Water Entry (perforations or screen setting at time of test)

Static Water Level (SWL) before test

Type of Pump (or Bailer) used

Depth of Pump intake

Discharge (in litres per minute)

Pumping Water Level (PWL)

After pumping continuously for

Time of Recovery to Original SWL

Rate of Recovery—WL after 5 minutes

20 minutes

60 minutes

180 minutes

Test No. 1	Test No. 2
100 metres	metres
from to m. m.	from to m. m.
40 metres	metres
MUNDALFI	
85 metres	metres
50 lpm.	lpm.
84 metres	metres
24 hours	hours
30 minutes	minutes
88 metres	metres
47 metres	metres
metres	metres
metres	metres

(Additional pumping tests to be mentioned in REMARKS and included with file).

Government representative witnessing the test

9. Quality of Water: Sample Yes, Collected at _____ hour on _____ (Date)
 No

Sediment, Taste salty, Odour
 Colour; Temperature °C.; Spec. Conductivity µmho/cm³.

10. Remarks: (drilling difficulties, gravel-pack details, all pertinent information about the drilling and completion of the hole);

(Signed) _____ (Signed) _____
 Drilling Supervisor Drilling Contractor

11. Driller's Log:

From (m.)	To (m.)	Drilling rate (m./hr.)	Description of formation penetrated
0	1		Top Sand
1	6		Sand
6	15		Lime Stone
15	80		Sand Stone
80	100		clay

(Geologist's log on attached sheets).

Borehole No. _____

12. Sketch of Borehole Construction:

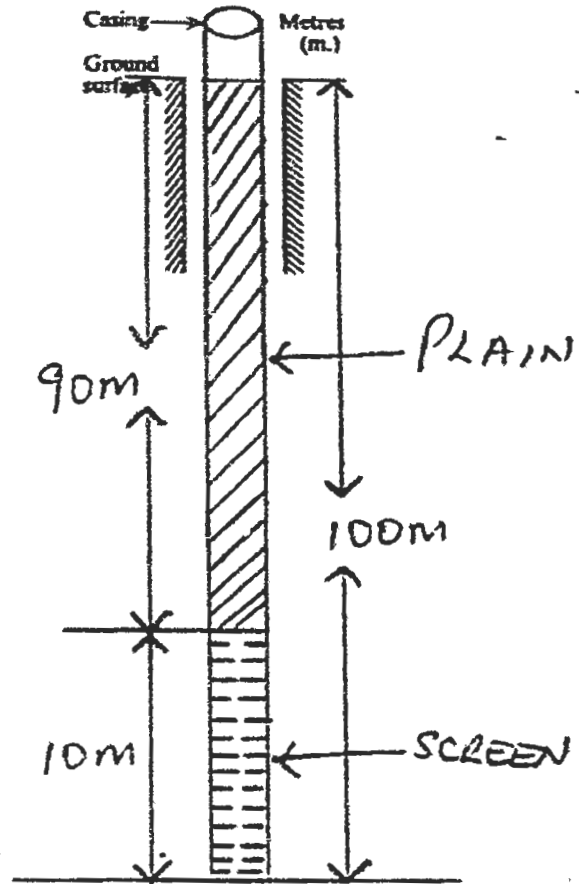

Remarks or additional information on Driller's log, or on sketch of borehole:

Total depth

(Sketch to include:—depth and changes of hole diameter; casing positions, manner of casing (of different diam.) connections, and casing connection to screen; depths of screens or slotted casing lengths; how casing is closed at bottom; formation caving zones; and any other pertinent information).



Borehole No. _____
Borehole Name RAGE-ELE
Formation _____

To be filled in TRIPPLICATE

1. Location: RAGE-ELE District: ADALE
Map Sheet: _____ Scale: _____ Coordinates: _____ N/S
Area: _____ E

(See sketch page 4) Elevation: _____ m. above msl.
2. Owner: RAGE-ELE COMMUNITY Address: SOMALIA
Locality/Estate: _____ L.R. No.: _____

Intended Use: — Public W S; Irrig.; Indust.; Domestic; Stock; Other: Domestic - STEEL
3. Contractor: DECA Address: _____
Licence No.: 114472 Gazetted on _____ : Drilling Supervisor: JOHN THORNTON
(Date)

4. Type of Borehole: — Drilled; Driven; Bored; Jetted; Other: Drilled
Type and Make of Drill Rig: WOOD BLOCK 155 - ROTARY

5. Borehole Construction (also see sketch page 3)
Drilling started: 22/93 (Date) Drilling completed: 22/94 (Date) All work completed: 22/94 (Date)
Total Depth: Reported: 125 m; Measured: 125 m; Final (back-filled) Depth: 71 m.
Hole Diameter: 542 mm. from _____ m. to 125 m.
mm. from _____ m. to _____ m.
mm. from _____ m. to _____ m.

Permanent Casing:
Plain:
Type: ELASTIC; Diam. 203 mm.; Length 510 m., from _____ m. to 125 m.
Type: PIPING; Diam. 152.4 mm.; Length 510 m., from _____ m. to 25 m.

Slotted or Perforated:
Size and Description of Openings
Type: ELASTIC; Diam. 152.4 mm.; Length 510 m., from _____ m. to 25 m.

Screen:
Type and Make: PERFORATED 152.4 ELASTIC
Diameter: 152.4 mm., Length 510 m., set from 49.80 m. to 50 m.

Gravel Pack:
Size of grains _____ mm., Roundness (good, fair, poor), Volume inserted in to annular space _____ cu. m., from _____ m. to _____ m.

Open Hole: Diameter _____ mm., from _____ m. to _____ m.
6. Aquifer: 1st Water Struck at 25 m.; Water rest level _____ m.
Main Aquifer Struck at 25 m.; Water rest level 22 m.
Water-bearing material: SAND, from 25 m. to 125 m.

Other Aquifers, Remarks, etc.:

(also see log on page 3)

7. Yield: SWL 23 m.; PWL 26 m. below surface; Discharge ~~250~~ 240 lpm., after pumping 24 hours; Recovered to SWL in 30 minutes; Recommended production discharge 14400 lph., with pump set at 54 m. below surface.

8. Pumping Test Record in Summary (Detailed test records on attached sheets): (all depth measurements to be in metres below ground surface).

	Test No. 1	Test No. 2
Date of Test (day, month, year)	<u>27/1/84</u>	
Depth of Borehole at time of test	<u>71</u> metres	metres
Water Entry (perforations or screen setting at time of test)	from m. to m.	from m. to m.
Static Water Level (SWL) before test	<u>23</u> metres	metres
Type of Pump (or Bailor) used	<u>ELE SUBMERSIBLE</u>	
Depth of Pump intake	<u>54</u> metres	metres
Discharge (in litres per minute)	<u>240</u> lpm.	lpm.
Pumping Water Level (PWL)	<u>26</u> metres	metres
After pumping continuously for	<u>24</u> hours	hours
Time of Recovery to Original SWL	<u>30</u> minutes	minutes
Rate of Recovery—WL after 5 minutes	<u>24.2</u> metres	metres
30 minutes	<u>24</u> metres	metres
60 minutes	metres	metres
180 minutes	metres	metres

(Additional pumping tests to be mentioned in REMARKS and included with file).

Government representative witnessing the test

9. Quality of Water: Sample Yes. Collected at _____ hour on _____ (Date)
No

Sediment _____ Taste SALTY Odour _____

Colour _____; Temperature _____ °C; Spec. Conductivity _____ (µmho/cm)

10. Remarks: (drilling difficulties, gravel-pack details, all pertinent information about the drilling and completion of the hole); 1 1/4 inch Hole Drilled to 102 metres. 8 inch (205 mm) Plastic Casing cemented to surface. Appears that hydrostatic pressure in hole caused plastic casing to collapse at 84 metres. Ran 6 inch liner into hole to 82 metres. Gravel pack section casing strings are from gravel, developed with RT 66 ml well washing. Gas plus E.P.M. increased for GAS, WATER SALT FREE.

(Signed)

Drilling Supervisor

(Signed)

Drilling Contractor

Borehole No. _____

11. Driller's Log:

12. Sketch of Borehole Construction:

From (m.)	To (m.)	Drilling rate (m./hr.)	Description of formation penetrated
0	2		LOOSE SAND
2	82		LIMESTONE SAND STREAMERS
82	125		MED TO FINE SANDS.

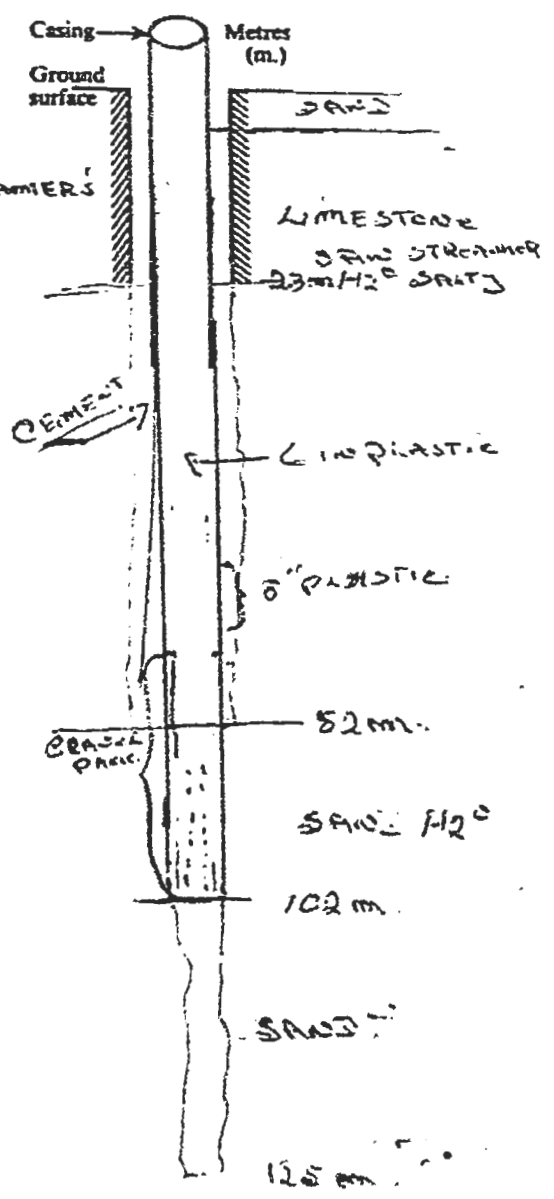

(Geologist's log on attached sheets).

Remarks or additional information on Driller's log, or on sketch of borehole:

Total depth

(Sketch to include:—depth and changes of hole diameter; casing positions, manner of casing (of different diam.) connections, and casing connection to screen; depths of screens or slotted casing lengths; how casing is closed at bottom; formation casing zones; and any other pertinent information).

Appendix

CONTRACTS OF RESPONSIBILITY



ADRA/SAACID SOMALIA
ADVENTIST DEVELOPMENT AND RELIEF AGENCY

Office in Kenya:
P.O. Box 14756
3 Riverside Drive, NAIROBI, Kenya
TEL. + 254-2-448392
FAX + 254-2-448391
Telex 23219 EAD/SDA

Office in Somalia:
Mogadishu North,
Karaan-district,
Compound of SAACID,
Khadija Ossoble Ali,
Hotel Nasa Hablood, K4

**CONTRACT OF RESPONSIBILITY
FOR THE WATER WELL AT**

MUHAMMAD SAID

The elders of the above mentioned community hereby contract with ADRA-SAACID concerning responsibility for the water well in their community.

1. The responsibility of ADRA-SAACID consists of the rehabilitation and/or construction of the well as follows:

- * drilling or rehabilitating the borehole,
- * installation or repairing of a diesel engine and pump,
- * construction or rehabilitation of livestock trough, water tank, public taps, all connected with pipes,
- * construction or rehabilitation of pump shelters and storage room,
- * give training in maintenance.

2. The responsibility of the community elders consists of the maintenance and protection of the well and its water yard as follows:

- * to appoint two persons for operating the well,
- * to elect five more persons forming a water committee. With the two well operators the committee will consist of 7 members, 4 men and 3 women. All decisions regarding the well, fees, repairs, maintenance etc. will be done by this committee.
- * to arrange all needed security for the well,
- * to be responsible for any repairs and maintenance that will be needed from time to time,
- * to give access to all village people, including surrounding nomads and people from neighbour villages.
- * to keep the well and the water yard in good order.

CONTRACT OF RESPONSIBILITY

3. This well is a donation from ADRA-SAACID and with the handing over of the keys to the elders, ADRA-SAACID has no further responsibility for this well. All future responsibility rests with the elders and the people of their community.

DATE: 5.1.94 LOCATION: MOHAMED SAID

A. COMMUNITY ELDERS:

Shukh Cal Sh. Nivasa
(print name)

[Signature]
(signature)

Max - 2 Calsson Haruur
(print name)

Maxamed. Calsson Haruur
(signature)

(print name)

(signature)

B. ADRA-SAACID:

FRANK BRENDA
(print name)

[Signature]
(signature)

Maxed Cabdulla Nivasa
(print name)

[Signature]
(signature)

C. MEMBERS OF THE WATER COMMITTEE:

1. Shukh Cal Sh. Nivasa (Chairman)
2. Xalim Cal Sh. Nivasa
3. Maxed Cabdulla Haruur
4. Cal Xalim Haruur
5. Rooli Xalim Haruur
6. Cal Haruur Cal (Operator)
7. Maxed Haruur Haruur (Operator)
8. Maxed Cal Yunsuf
9. Xalim Maxed Haruur
10. Cal Xalim Haruur
11. Haruur Xalim Haruur
12. Maxed Haruur Haruur



ADRA/SAACID SOMALIA
ADVENTIST DEVELOPMENT AND RELIEF AGENCY

Office in Kenya:
P.O. Box 14756
3 Riverside Drive, NAIROBI, Kenya
TEL. + 254-2-448392
FAX + 254-2-448391
Telex 23219 EAD/SDA

Office in Somalia:
Mogadishu North,
Karaan-district,
Compound of SAACID,
Khadija Ossoble Ali,
Hotel Nasa Hablood, K4

**CONTRACT OF RESPONSIBILITY
FOR THE WATER WELL AT**

ADALE

The elders of the above mentioned community hereby contract with ADRA-SAACID concerning responsibility for the water well in their community.

1. The responsibility of ADRA-SAACID consists of the rehabilitation and/or construction of the well as follows:

- * drilling or rehabilitating the borehole,
- * installation or repairing of a diesel engine and pump,
- * construction or rehabilitation of livestock trough, water tank, public taps, all connected with pipes,
- * construction or rehabilitation of pump shelters and storage room,
- * give training in maintenance.

2. The responsibility of the community elders consists of the maintenance and protection of the well and its water yard as follows:

- * to appoint two persons for operating the well,
- * to elect five more persons forming a water committee. With the two well operators the committee will consist of 7 members, 4 men and 3 women. All decisions regarding the well, fees, repairs, maintenance etc. will be done by this committee.
- * to arrange all needed security for the well,
- * to be responsible for any repairs and maintenance that will be needed from time to time,
- * to give access to all village people, including surrounding nomads and people from neighbour villages.
- * to keep the well and the water yard in good order.

CONTRACT OF RESPONSIBILITY

3. This well is a donation from ADR -SAACID and with the handing over of the keys to the elders, ADRA-SAACID has no further responsibility for this well. All future responsibility rests with the elders and the people of their community.

DATE: 21.2.1994 LOCATION: ADALE

A. COMMUNITY ELDERS:

Haji Ali Fido
(print name)

[Signature]
(signature)

Abu Said Ahmed Mohamed
(print name)

[Signature]
(signature)

(print name)

(signature)

B. ADRA-SAACID:

Abdul Qadir M. Nur
(print name)

[Signature]
(signature)

FRANK BREIDA
(print name)

[Signature]
(signature)

C. MEMBERS OF THE WATER COMMITTEE:

- 1. Haji Ali Fido (Chairman)
- 2. Ahmed Ali Ahmed
- 3. Mohamed Barro Gedi
- 4. Ahmed Ahmed Mohamed
- 5. Ahmed Adlan Ali
- 6. Said Mohamed Omar (Operator)
- 7. Fadwa Abd Ali (Operator)
- 8. Issa Mohamed Nur
- 9. Mohamed Omar Fidi - operator
- 10. Mohamed Abd -



ADRA/SAACID SOMALIA
ADVENTIST DEVELOPMENT AND RELIEF AGENCY

Office in Kenya:
P.O. Box 14756
3 Riverside Drive, NAIROBI, Kenya
TEL. + 254-2-448392
FAX + 254-2-448391
Telex 23219 EAD/SDA

Office in Somalia:
Mogadishu North,
Karaan-district,
Compound of SAACID,
Khadija Osoble Ali,
Hotel Nasa Hablood, K4

**CONTRACT OF RESPONSIBILITY
FOR THE WATER WELL AT**

BUR DAACAR

The elders of the above mentioned community hereby contract with ADRA-SAACID concerning responsibility for the water well in their community.

1. The responsibility of ADRA-SAACID consists of the rehabilitation and/or construction of the well as follows:

- * drilling or rehabilitating the borehole,
- * installation or repairing of a diesel engine and pump,
- * construction or rehabilitation of livestock trough, water tank, public taps, all connected with pipes,
- * construction or rehabilitation of pump shelters and storage room,
- * give training in maintenance.

2. The responsibility of the community elders consists of the maintenance and protection of the well and its water yard as follows:

- * to appoint two persons for operating the well,
- * to elect five more persons forming a water committee. With the two well operators the committee will consist of 7 members, 4 men and 3 women. All decisions regarding the well, fees, repairs, maintenance etc. will be done by this committee.
- * to arrange all needed security for the well,
- * to be responsible for any repairs and maintenance that will be needed from time to time,
- * to give access to all village people, including surrounding nomads and people from neighbour villages.
- * to keep the well and the water yard in good order.

CONTRACT OF RESPONSIBILITY

3. This well is a donation fr. ADRA-SAACID and with the handing over of the keys to the elders, ADRA-SAACID has no further responsibility for this well. All future responsibility rests with the elders and the people of their community.

DATE: 12-12-93 LOCATION: Bur C.A.C.-R

A. COMMUNITY ELDERS:

1. NABADAN umar handudades
(print name) (signature)

2. NABADAN Muhammad bin Abdul Kadir
(print name) (signature)

(print name) (signature)

B. ADRA-SAACID:

ABDUL KADIR M. BUR [Signature]
(print name) (signature)

FRANK BRENDA [Signature]
(print name) (signature)

C. MEMBERS OF THE WATER COMMITTEE:

1. Muhammad bin Abdul Kadir (Chairman)
 2. [Signature]
 3. [Signature]
 4. [Signature]
 5. [Signature]
 6. [Signature] (Operator)
 7. [Signature] (Operator)
- S. M. D. I. M. J. I. M. H. A. D. A. S. E.



ADRA/SAACID SOMALIA
ADVENTIST DEVELOPMENT AND RELIEF AGENCY

Office in Kenya:
P.O. Box 14756
3 Riverside Drive, NAIROBI, Kenya
TEL. + 254-2-448392
FAX + 254-2-448391
Telex 23219 EAD/SDA

Office in Somalia:
Mogadishu North,
Karaan-district,
Compound of SAACID,
Khadija Ossoble Ali,
Hotel Nasa Hablood, K4

**CONTRACT OF RESPONSIBILITY
FOR THE WATER WELL AT**

ALI GUDUUD

The elders of the above mentioned community hereby contract with ADRA-SAACID concerning responsibility for the water well in their community.

1. The responsibility of ADRA-SAACID consists of the rehabilitation and/or construction of the well as follows:

- * drilling or rehabilitating the borehole,
- * installation or repairing of a diesel engine and pump,
- * construction or rehabilitation of livestock trough, water tank, public taps, all connected with pipes,
- * construction or rehabilitation of pump shelters and storage room,
- * give training in maintenance.

2. The responsibility of the community elders consists of the maintenance and protection of the well and its water yard as follows:

- * to appoint two persons for operating the well,
- * to elect five more persons forming a water committee. With the two well operators the committee will consist of 7 members, 4 men and 3 women. All decisions regarding the well, fees, repairs, maintenance etc. will be done by this committee.
- * to arrange all needed security for the well,
- * to be responsible for any repairs and maintenance that will be needed from time to time,
- * to give access to all village people, including surrounding nomads and people from neighbour villages.
- * to keep the well and the water yard in good order.

CONTRACTOR'S RESPONSIBILITY

3 This well is a donation from ADRA-SAACID and with the handing over of the keys to the elders, ADRA-SAACID has no further responsibility for this well. All future responsibility rests with the elders and the people of their community.

DATE: 14/12/93 LOCATION: ALI GUDUUD

A. COMMUNITY ELDERS:

Ch. Maxamed Maxamed Caliif
(print name) (signature)

Ow Gadoosow Cali Cali Calif
(print name) (signature)

(print name) (signature)

B. ADRA-SAACID:

ABDULKADIR M. HUR [Signature]
(print name) (signature)

FRANK BRENDA [Signature]
(print name) (signature)

C. MEMBERS OF THE WATER COMMITTEE:

1. ~~Xasan Maxamed Cali~~ (Chairman)
2. ~~Muqtaar Maxamed Cali~~
3. ~~Mahdi Jimcaah Maxamed~~
4. ~~Ruqiya Maxamed Xusein~~
5. ~~Ow Maxamed Shiq Maxamed~~
6. ~~Maxamed Xasan Rooble~~ (Operator)
7. ~~ANBIYO OW CALI CASHE~~ (Operator)



ADRA/SAACID SOMALIA
ADVENTIST DEVELOPMENT AND RELIEF AGENCY

Office in Kenya:
P.O. Box 14756
3 Riverside Drive, NAIROBI, Kenya
TEL. + 254-2-448392
FAX + 254-2-448391
Telex 23219 EAD/SDA

Office in Somalia:
Mogadishu North,
Karaan-district,
Compound of SAACID,
or Hotel Nasa Hablood
near Km 4

**HESHIIS MAS'UULIYADEED
KU SAABSAN CEELKA BIYAHA EE**

Duqeyda bulshada kor ku xusan waxaa halkaan heshiis kula galaya ADRA/SAACID, heshiiskaa oo khuseeya mas'uuliyadda ceel biyoodka bulshadooda.

1. Mas'uuliyadda ADRA/SAACID oo ka kooban dib u dayactirka iyo/ama dhismo ceel waa sida soo socoto:

- * Qodista ama dib u dayactirka ceelasha dheer.
- * Rakibid ama dayactirka matoorada naftadda ah iyo bambooyinka.
- * Dhismaha ama dayactirka barkadaha xoolaha, haamaha biyaha, rubinootooyinka dadweynaha, kuwaasoo dhamaan tubooyin kuwada xiran yihiin.
- * Dismaha ama dib u hagaajinta qolalka bambooyinka iyo qolka keydka alaabta.
- * Tababar siinta farsamada ceelka.

2. Mas'uuliyada duqeyda bulshada oo ka kooban, hagaajinta iyo difaaca ceelka, iyo aaga biyaha waa sida soo socoto:

- * In loo magacaabo labo qof oo ka shaqeyso ceelka.
- * In loo doorto 5 qof oo noqon doono guddiga ceelka. Marka lagu daro labada ka shaqeyn doonto wuxuu ka koobnaan doonaa 7 xubnood, 4 rag ah iyo 3 haween ah. Go'aamada dhamaan ku saabsan ceelka, lacagta la qaadayo, dib u hagaajinta, dowlista iyo i.w.m. Waxaa qaban doono guddiga.
- * In ay qaban qaabiyaan dhamaan wixii nabad galyada ceelka looga baahan yahay.
- * In ay mas'uul ka noqdaan wax kasto oo dib u hagaajin ah, iyo dhowritaanka oo loo baahan doono waqti walbo.
- * In ay u fududeeyaan dhamaan dadka tuulada, oo ay ku jiraan reer miyiga ku wareegsan, iyo dadka tuulooyinka dariska la ah.
- * In ay xafidaan ceelka iyo aaga biyaha kuna xafidaan nidaam wanaagsan.

3. Ceelkan waa deeq ka timid ADRA/SAACID iyadoo gaacanta loo galin doono furaha duqeyda tuuladda, ADRA/SAACID wax dambe oo xil ah kama saarnaan doono ceelka. Mustaqbalka wixii mas'uuliyad ah waxay saaran tahay duqeyda iyo bulshada tuuladda.

TAARIIKH ----- MEESHA -----

A. DUQEYDA BULSHADA:

Magaca oo buuxo Saxiixa

Magaca oo buuxo Saxiixa

B. ADRA/SAACID

Magaca oo buuxo Saxiixa

Magaca oo buuxo Saxiixa

C. XUBNAHA GUDDIGA BIYAHA:

- 1.----- Guddoomiye
- 2.-----
- 3.-----
- 4.-----
- 5.-----
- 6.----- (Farsamayaqaan)
- 7.----- (Farsamayaqaan)

Appendix

PUMP INFORMATION

H₂O WASTE-TEC

H₂O WASTE-TEC

Horsfield Way Bredbury Park Stockport SK6 2SU UK
Tel: 061 406 7111 Fax: 061 406 7222 Tlx: 669707

ROBERT O'RAW
International Sales Manager

Mono[®] Subrotor The Real Alternative

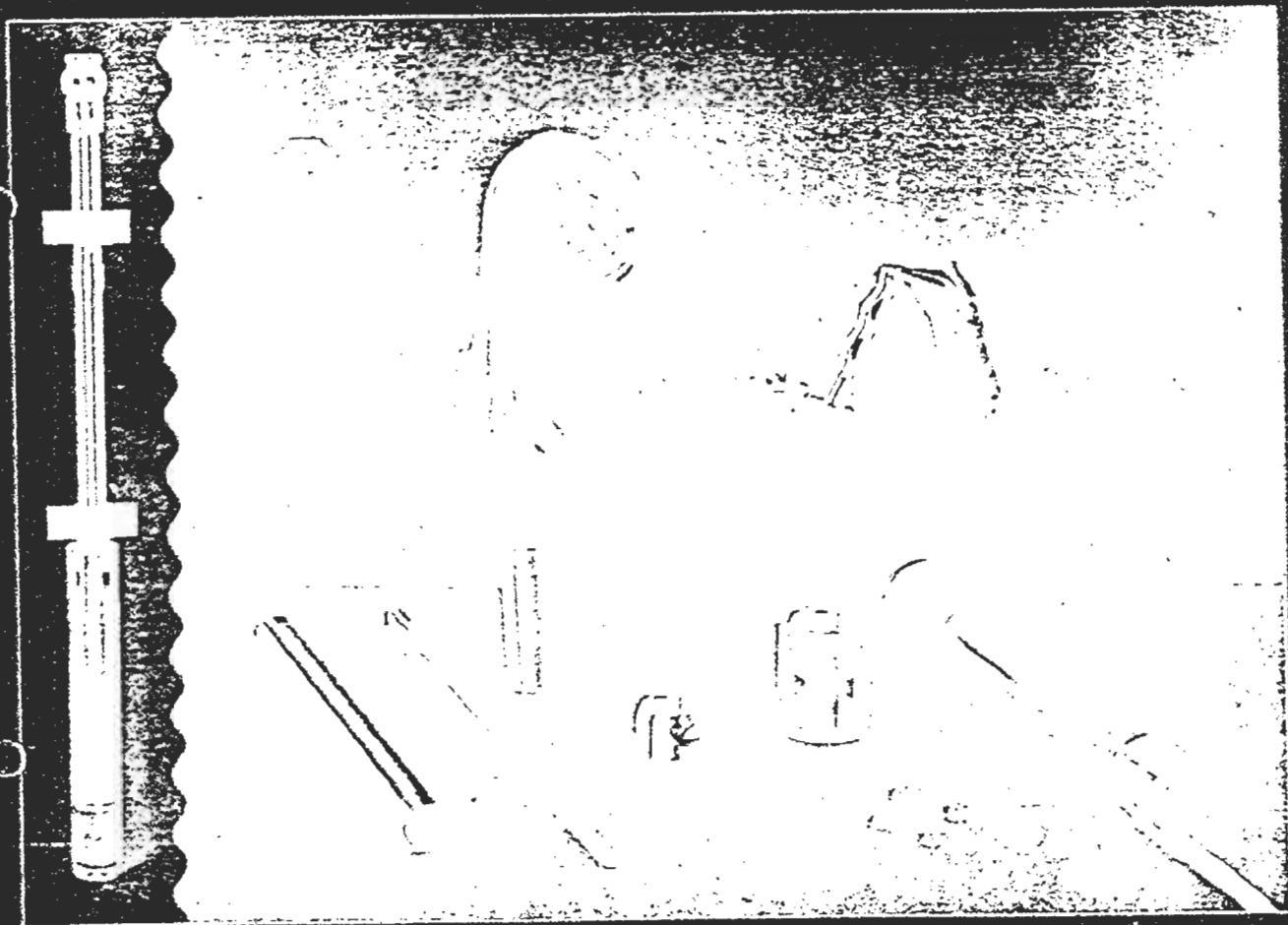

Mono Pumps

DRESSER

The Real Alternative

The Mono[®] Subrotor pump from H₂O Waste-Tec offers the first real alternative to multi-stage centrifugal borehole pumps.

Unlike the conventional borehole pump which uses centrifugal force as the energy to move the water, the Mono[®] Subrotor uses the Progressing Cavity Rotor/Stator Principle to draw water up through it.

When the hard chrome plated rotor lays inside the rubber stator the two components touch along a ribbon of contact, behind which is a sealed capsule that moves from suction to discharge as the rotor rotates inside the stator. The air or liquid within the capsule is delivered so positively that the pump is capable of very high pressure.

The Mono[®] pumping principle was invented in the 1930's, and has continued to be developed and refined to meet the increasing needs of the world's pumping industries.

The progressing cavity principle is one of the most efficient and reliable methods of pumping water ever developed by man. The design principle ensures that the pumps are also extremely reliable and can usually be expected to outlast multi-stage pumps, particularly on borehole water with a sand or silt content.



A User Friendly Forgiving Pump



More Flow at Higher Heads
The Mono system doesn't just spin water along. It pushes encapsulated water with positive force, so that ample volume is maintained at high heads.

More Water, Lower Energy Bills
Mono Subrotor pumps waste the least possible energy on internal friction, especially compared to multi-stage and jet pumps.

in a conventional centrifugal pump, the impellers and diffusers work one after the other to create a little extra pressure at each stage. Power is wasted at every stage, and when one stage wears, the pump stops!

Easy Maintenance
Unlike centrifugal pumps, the Subrotor has only one moving pump part - the rotor. Its companion, the rubber stator is also very resistant to wear and can easily be replaced with just a wrench.

Self Cleaning
The rotor sweeps the full surface of the rubber stator every turn. It is impossible for growth or iron oxide deposits etc. to develop there.

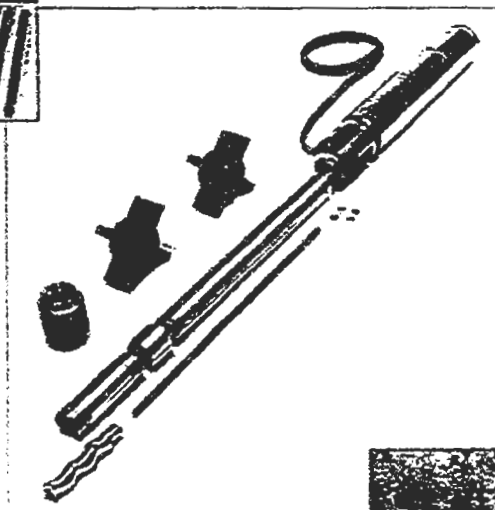

Harder Stainless
Mono's chrome plated, stainless rotors are up to 4 times harder than the stainless you find in centrifugal pumps.

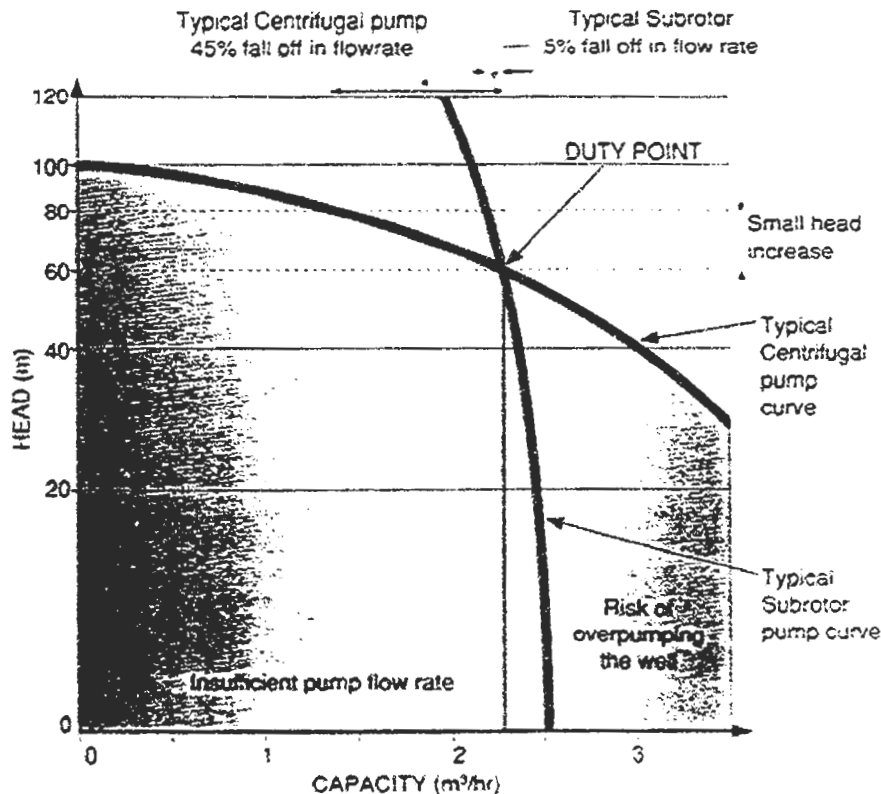
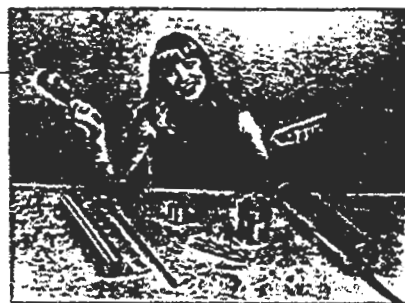

Stable Pump Curve
Small variations to the pump head due to seasonal fluctuations or depth of the water table, or perhaps just a simple personal miscalculation of the pump total head, could have a serious effect to the performance of a centrifugal pump.

No such problem arises if you have chosen the forgiving Mono Subrotor pump. Positive pumping of the progressing cavity action delivers sufficient water when it's needed most, even during the dry season and likely drop in water table. Conversely it will not over pump the well if water table rises and therefore pump head drops.

Performance Curves and Coding Table

FEATURES	DESCRIPTION	BASIC CODE				FIELD VARIATION	
PRODUCT	SUBROTOR PUMP	SR					
MARK NO.	1993 MARK 1	1					
PUMP CAPACITY AT ZERO BAR HEAD	150 litres/min 100 litres/min 80 litres/min 40 litres/min 20 litres/min		15 10 08 04 02				
ROTOR STATOR STAGES	SINGLE (75m max head) TWO (150m max head)		1 2				
MOTOR POWER	0.75 kW 1.10 kW 1.50 kW 2.20 kW			Y Z A B			
POWER SUPPLY	SINGLE PHASE (240V) SINGLE PHASE (220V) THREE PHASE (380/415V)				1 2 3		
OBLIQUE						/	
FIELD VARIATION							
EXAMPLE OF TYPICAL CODING		SR	1	10	1	A	1

NOTE: AN 'X' IN ANY COLUMN DENOTES A CUSTOMIZED UNIT

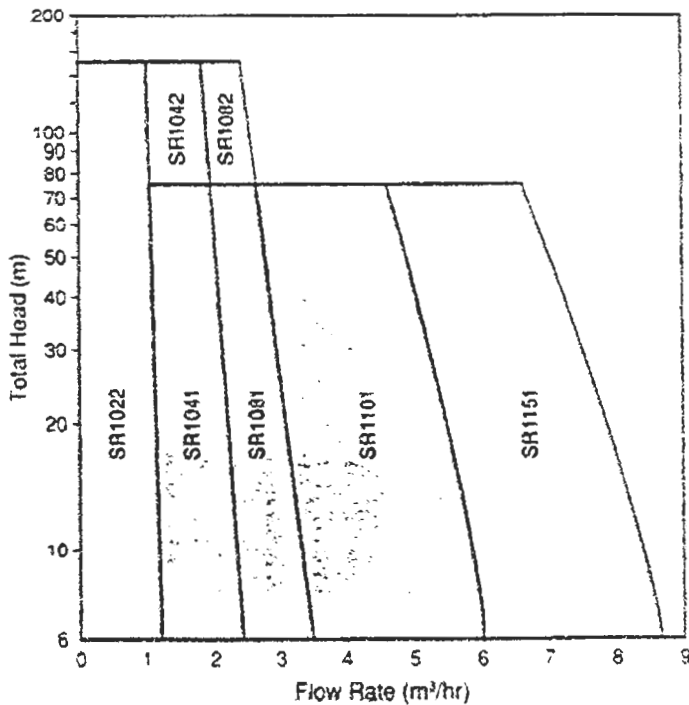

Technical Data

Operating Conditions

To ensure optimum performance, the following operating conditions should be observed:-

Maximum water temperature 30°C

Maximum ambient temperature for control box starter 50°C

All Subrotor pumps are suitable for installation in boreholes of 100mm diameter or larger.

Stabilisers are supplied over size to be trimmed on-site to fit borehole.

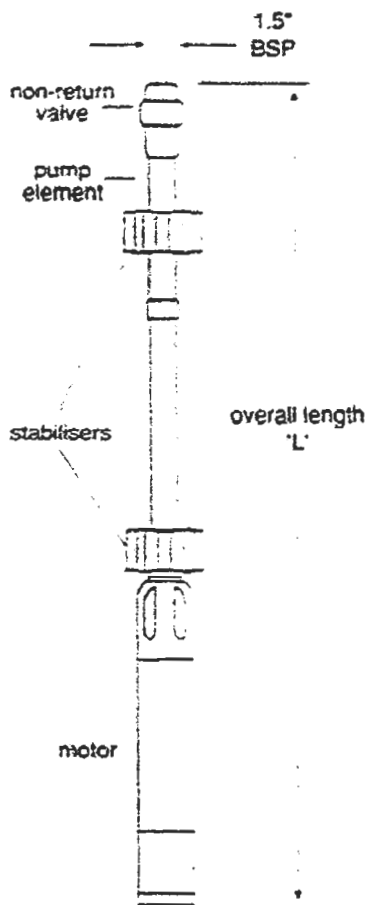

MODEL NO.	No. OF STAGES	MOTOR DETAILS			VOLTS	RATED CURRENT AMPS	APPROX 'L' mm	APPROX WT. kg
		kW	HP	phase				
SR1022Y1	2	0.75	1.0	1	240	5.4	1270	20
SR1022Y2	2	0.75	1.0	1	220	6.5	1270	20
SR1022Y3	2	0.75	1.0	3	415	2.0	1240	20
SR1041Y1	1	0.75	1.0	1	240	5.4	1260	19
SR1041Y2	1	0.75	1.0	1	220	6.5	1260	19
SR1041Y3	1	0.75	1.0	3	415	2.0	1230	19
SR1042A1	2	1.5	2.0	1	240	10.8	1350	20
SR1042A2	2	1.5	2.0	1	220	11.8	1350	20
SR1042A3	2	1.5	2.0	3	415	3.8	1320	20
SR1081Z1	1	1.1	1.5	1	240	8.7	1300	20
SR1081Z2	1	1.1	1.5	1	220	9.4	1300	20
SR1081Z3	1	1.1	1.5	3	415	2.9	1260	20
SR1082B1	2	2.2	3.0	1	240	14.0	1390	21
SR1082B2	2	2.2	3.0	1	220	15.1	1390	21
SR1082B3	2	2.2	3.0	3	415	5.3	1320	21
SR1101A1	1	1.5	2.0	1	240	10.8	1370	21
SR1101A2	1	1.5	2.0	1	220	11.8	1370	21
SR1101A3	1	1.5	2.0	3	415	3.8	1320	21
SR1151B1	1	2.2	3.0	1	240	14.0	1430	22
SR1151B2	1	2.2	3.0	1	220	15.1	1430	22
SR1151B3	1	2.2	3.0	3	415	5.3	1370	22

To identify pump from part Number eg. SR1101A1: SR (Subrotor), 1 (Mark 1), 10 (100 litres/min), 1 (stage), A (1.5kW), 1 (single phase 240V) See Coding Table. NB. All 3 phase motors will operate on 380V or 415V

Submersible Cable Selection Chart

CABLE SIZE	SINGLE PHASE MOTORS 240V, 220V 50Hz							THREE PHASE MOTORS		
	1.5	2.5	4.0	6.0	10.0	16.0	25.0	1.5	2.5	4.0
0.75 kW	40m	65m	105m	160m	350m	500m	750m	240m	-	-
1.10 kW	30m	50m	75m	115m	190m	350m	530m	180m	285m	-
1.50 kW	22m	36m	60m	90m	145m	270m	410m	135m	225m	360m
2.20 kW	-	30m	48m	72m	120m	170m	260m	100m	165m	255m
MAXIMUM PERMISSIBLE LENGTH (METRES) FROM MOTOR TO CONTROL BOX										

Accessories

Accessories Available

Single phase control box
D.O.L. starter for three phase supply
Bore cap (to suit up to 150mm)
Flow inducer tube
Electric power cable
Cable joining kits
Flexible rising main
Galvanised steel rising main
Stainless steel suspension wire

Also available is a fully automatic on/off pressure kit, designed to complement the Subrotor range. Each kit comprises of a pressure tank, pressure switch, pressure gauge and tee fitting.

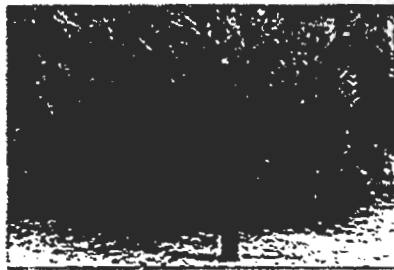
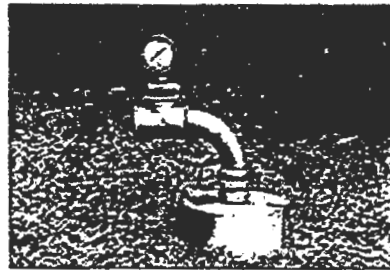
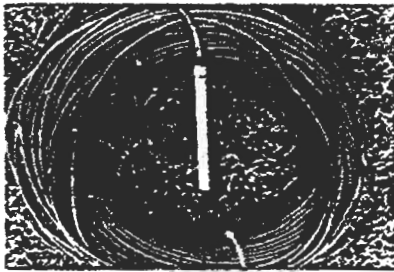
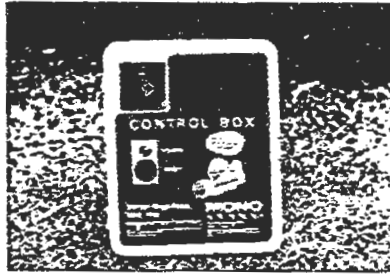

Published information other than that marked CERTIFIED is to be used as a guide only.
Mono® is a registered trademark of Mono Pumps Ltd.

H₂O WASTE-TEC

Horsfield Way Bredbury Park Stockport SK6 2SU UK
Tel: 061 406 7111 Fax: 061 406 7222 Tlx: 669707

Mono Pumps

DRESSER



Registered Office: Kings Road
Stockport, Greater Manchester M12 6JQ
Telephone: 0161 275 2221



We also anticipated that we could ship the goods on Vessel Lucy sailing on the 18 January 1994. Regrettably the space available was fully booked. The next sailing was the DSR African Sun scheduled to leave Felixstowe 27 January 1994 ETA 21 February 1994 and the goods are on this vessel.

The majority of the goods were ready for despatch on time regrettably, as we were consolidating the shipment we had to wait until all the equipment was built and inspected. A delay was also experienced from our engine supplier as they had closed down for two weeks due to the Christmas holiday.

When we offered our official quotation(s) we stated a minimum delivery period for item a) and b) as 4 working weeks. The lead time for item c) was of 6 to 8 working weeks from receipt of official order.

Item	Contract No	Date received	Acknowledged delivery date	Actual delivery
a)	CO93352	29 Oct 1993	10 Dec 1993	10 Jan 1994
b)	CO93554	02 Nov 1993	10 Dec 1993	10 Jan 1994
c)	CO93574	15 Nov 1993	10 Dec 1993	10 Jan 1994

Our contract references are as follows:-

As you are aware, we have processed three borehole diesel driven pump orders destined for ADRA projects in Somalia that are for the emergency relief programme.

RE: EMERGENCY PUMPS FOR ADRA

Dear Sirs,

TO WHOM IT MAY CONCERN

23 February 1994
ROR/MB NUR

Dega Construction Company
c/o Hotel Mesa-Habid
Mogadishu
Somalia

Horsfield Way, Sprobury Park, Stockport, SK6 2SU, UK
Tel: 061 406 7111 Fax: 061 408 7222 Tlx: 669707



H₂O WASTE-TEC

H₂O WASTE-TEC

Dega Construction Co/2

We are sure you agree that the delays were not caused by either Dega Construction or our company and were beyond our control.

We apologise for any inconvenience this delay may have caused and look forward to cooperating with you in the future.

Yours faithfully,



R O'Raw
International Sales Manager

Mono Pumps (DRESSER)

Appendix

WARGAADHI VILLAGE LETTER

Translation

Dec. 1, 1993

From: Wargaadhi village, one of the villages in the Adale district.

To: The Humanitarian Agency of Water.

Request:

We need one motor to be fixed at one well which is the same as Gel-Gub, Bur-Da'ar, Ali Gudud, and Mahamed-Said villages.

This request was written by the traditional rulers, the religious leaders (sheqs), the peace-makers and the youth of the village. Some of their names are;

(List of 30 names)

Ka. Tuulada Wargadaa ee ka Tirsan d. Cadale
 Ka. Hojarta gargaarka Banna adantimo ee Biyaha
 Cabdi Waxaan u Barakonaqay hal matoor
 IN Naloo Mude Kaasee Eamid ah sida
 geel job iyo Burdaaor iyo Cal guduu
 iyo Muxamad Siid artigaas Waxaa soo gaway
 akhyaarta Jooqta Wargadaa iyo Calaa udiinka
 iyo gudiga iyo Samadoo Nada iyo dhalin yaraada
 Waxaanu ka mid ah dal kaas aan soo sheegay

1) Xaaf. Shaxul Xundubey

2) Shiikh Yuusuf ee waa gacal

3) Shiikh Abuukar Maalin

4) Maxamad Cumar Kaayob

5) Cumar Maalin dhicsoo

6) Cabdulle Maxamuud Kaayob

7) Cusub oo Maxamuud Kaayob

8) Maxamuud Maxamuud Cabdulla

10) Cabir Cumar Cabdullah aybakar

11) Cali w/ ahmed Tifoch

12) Maxamed Sugulay Cabdullah

13) Geesey w/ ahmed

14) Maxamuud Xasan Jambaye

15) Maxamuud Xasan Ciislaan

16) Cabasow Maxamuud Mahadale

17) Ibrahim Maxamuud Xaarijow

18) Cali Jilacow Maxamuud

19) Maxamed ahmed Jiile

20) Abukar ahmed w/ galal

21) Cali Xasan goGaneey

22) Xaasan Cabdulle Xaasan

23) Maxamed ahmed Cabd.

24) Maxamed Shukriya Xaadiin

25) Maxamed Cabdulle Xaaso

26) w/ Xaasan Cali Cabdullah

27) Cabdulle di Xaasan Xaarijow

28) Maxamuud Rooble Maxamuud

29) Maxamuud Abukar Cumar

30) Maxamuud Maxamuud Jiile

31) Maxamuud Cali Xaasan Maxamuud

PHOTO APPENDIX

The first picture was taken at the village of Hagi Ali. The livestock trough for camels is filled with water. The second picture depicts a cattle trough, which is much lower than that of a camel trough. picture taken at Ali Gudud.



Photo 1

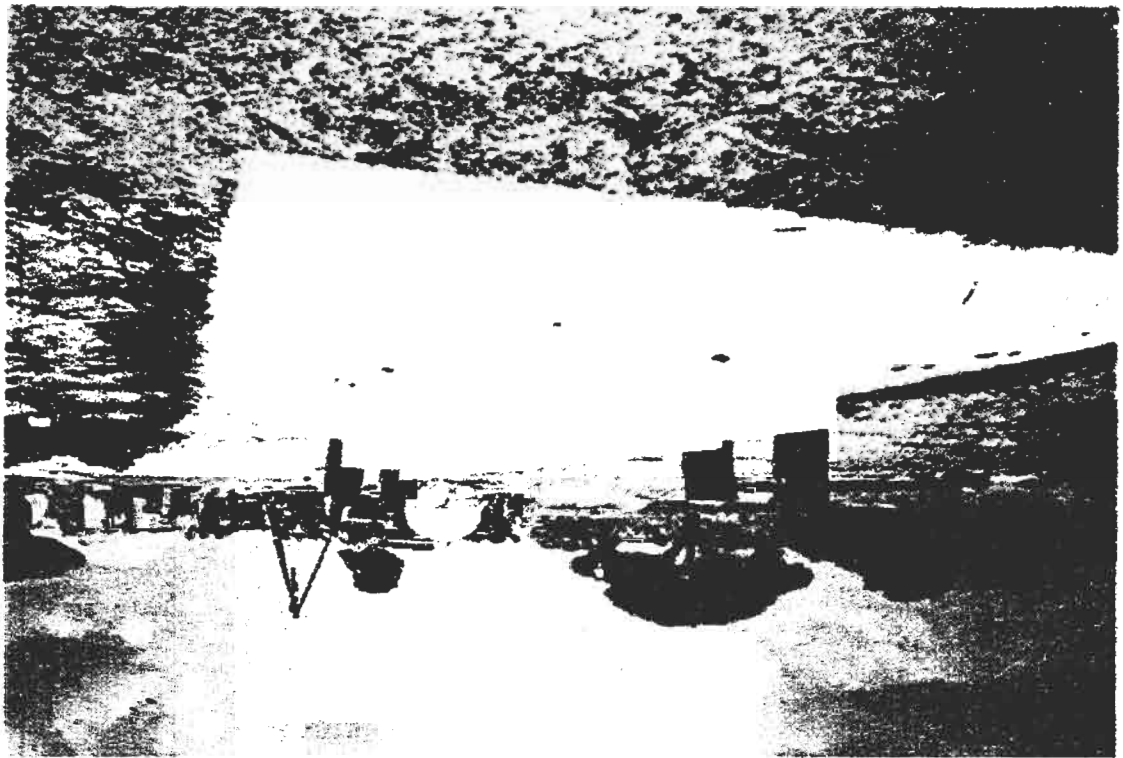

A livestock trough, designed for camels. The camel trough were made higher than that for cattle, goats and sheep. The two pictures depict the view from above and view from a ground level.

Picture one depicts old water tank of Geel-Gub. The following picture depicts a newly installed water tank. This is a type of the water tanks we purchased from Oxfam.

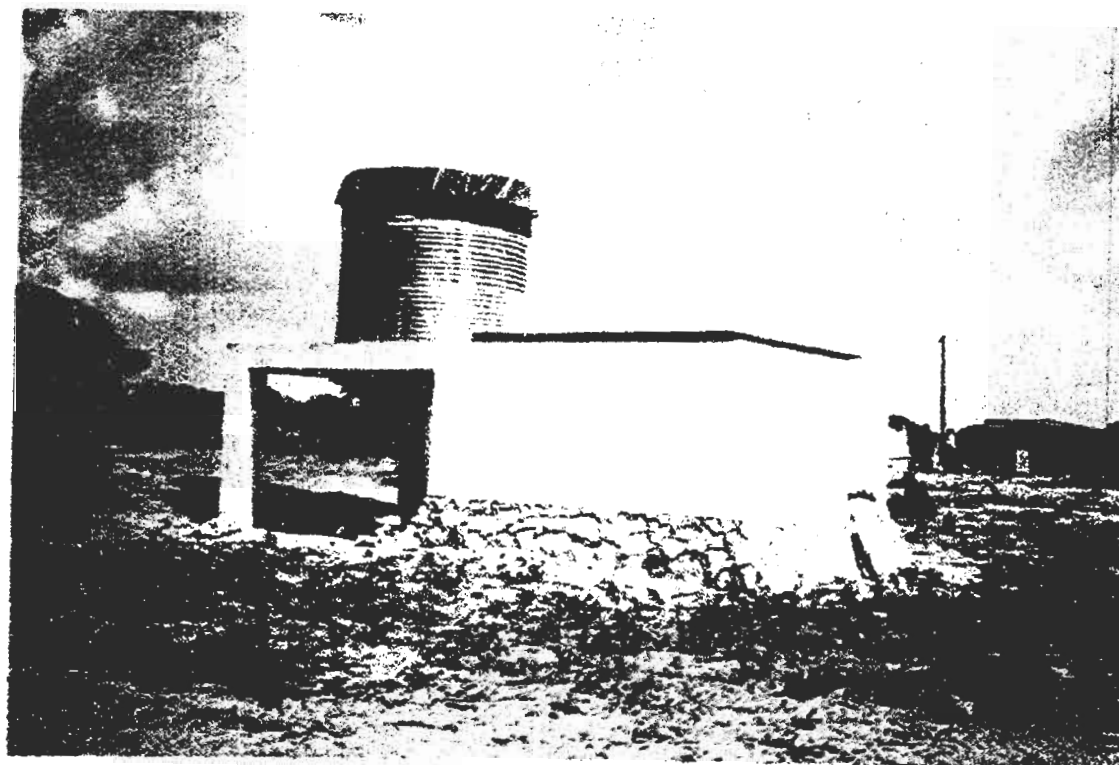

Photo 3

The provision of clean/potable water to both livestock and humans is major objective of ours. The following depicts a destroyed water distribution point in one of the villages. The next picture depicts a restored water distribution point with six outlets. This model was used in all the villages.

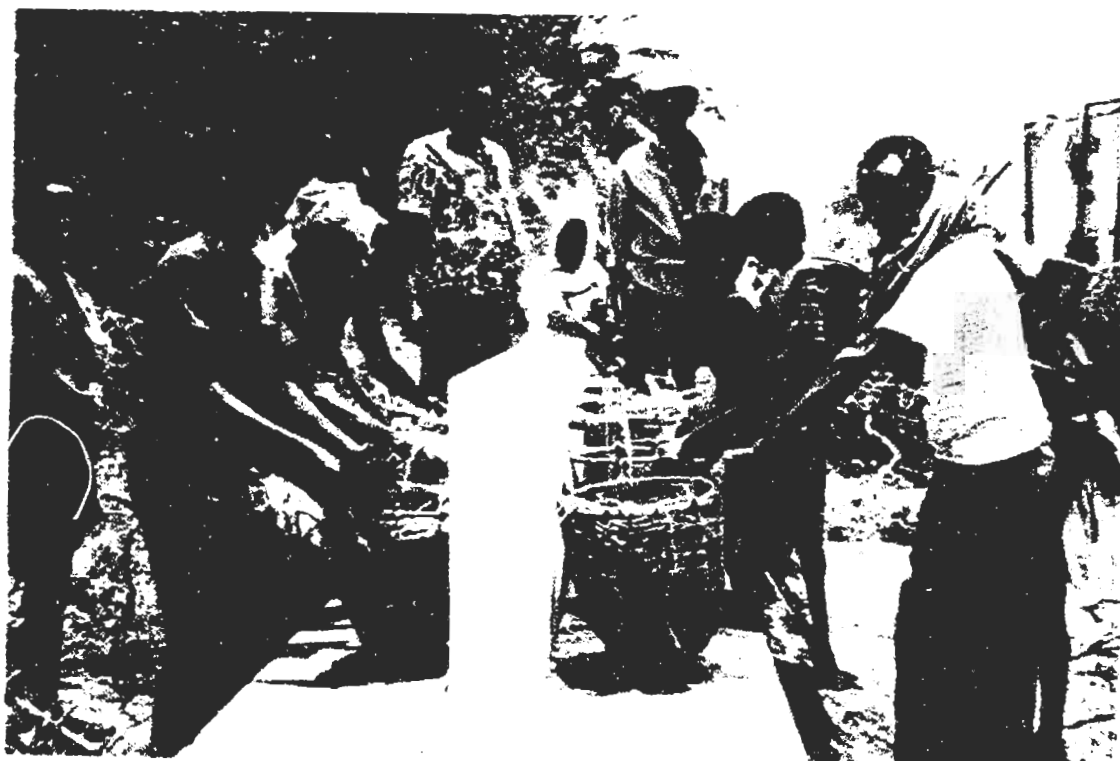

Photo 4

ADRA always considered the most efficient method of providing water to communities. The first picture depicts an engine driven pump that operates on diesel fuel. Th Monolift pump and engine pumps 10,000 litres of water in an hour at \$1.00. The second picture depicts a more economical mechanism for pumping water. This windmill was installed at Adala town, It coastal location made this option the best choice.

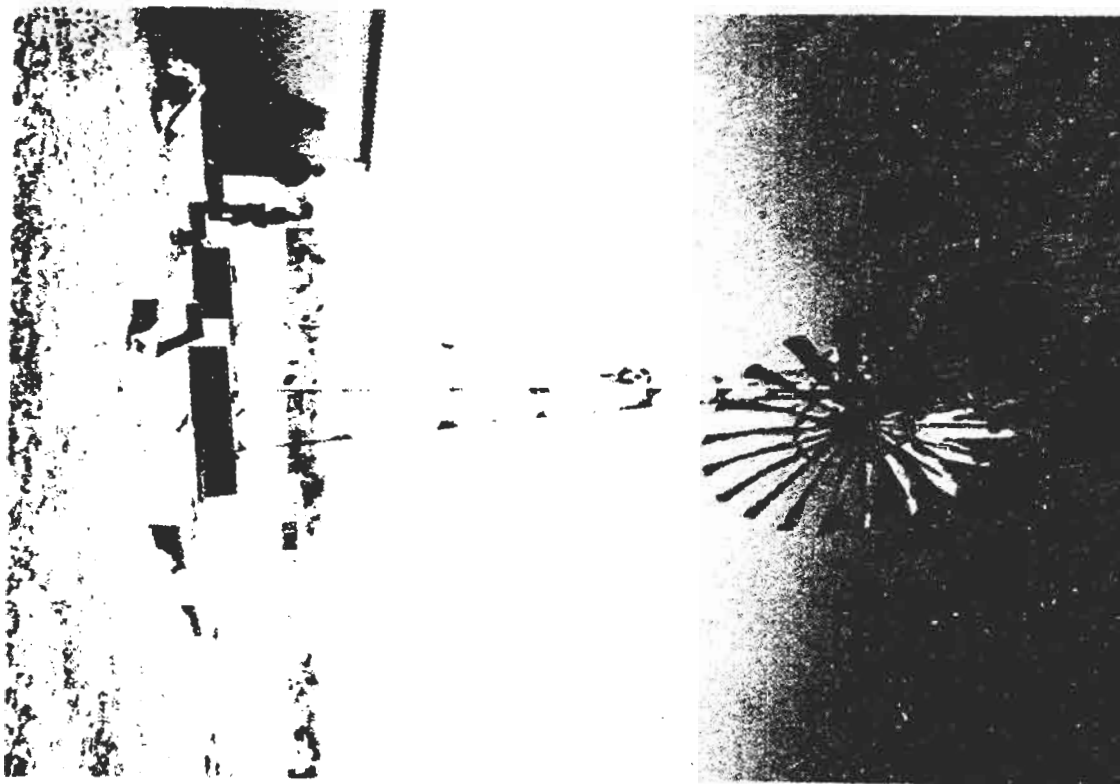
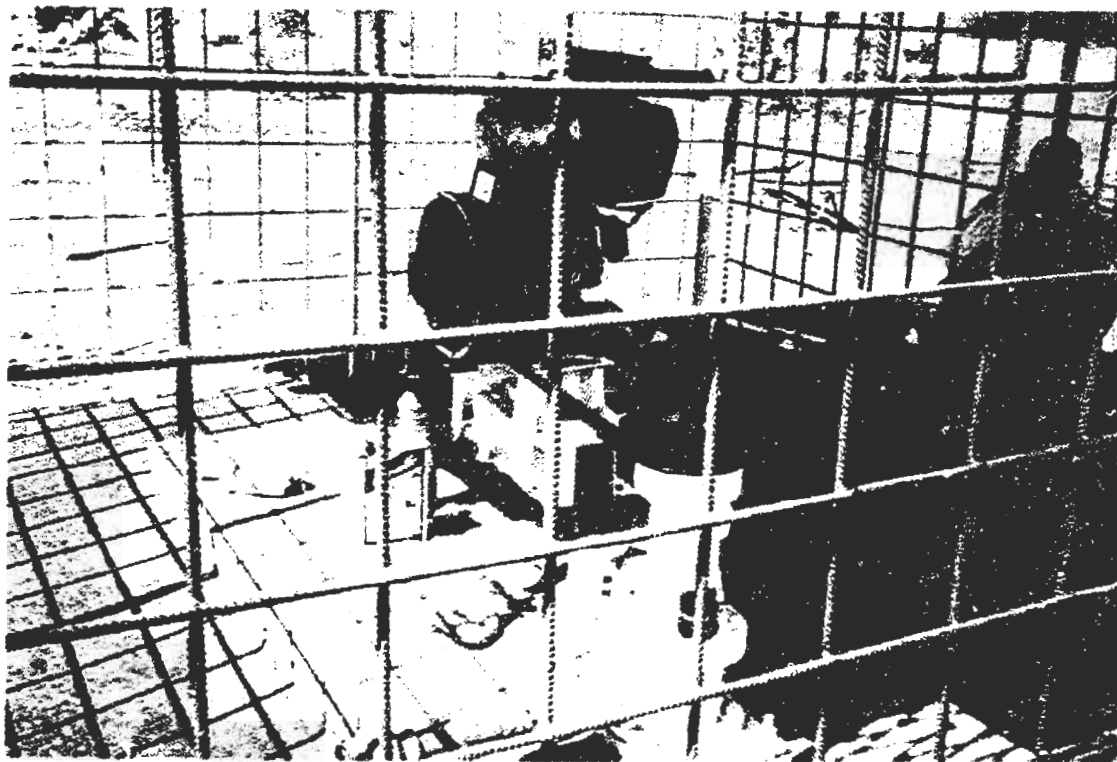

Photo 5

The drilling tasks was accomplished by two drilling Rigs. The first drilling rig was not dependable, hence our contractor purchased a second rig, which was very reliable. The pictures depict the team at work.

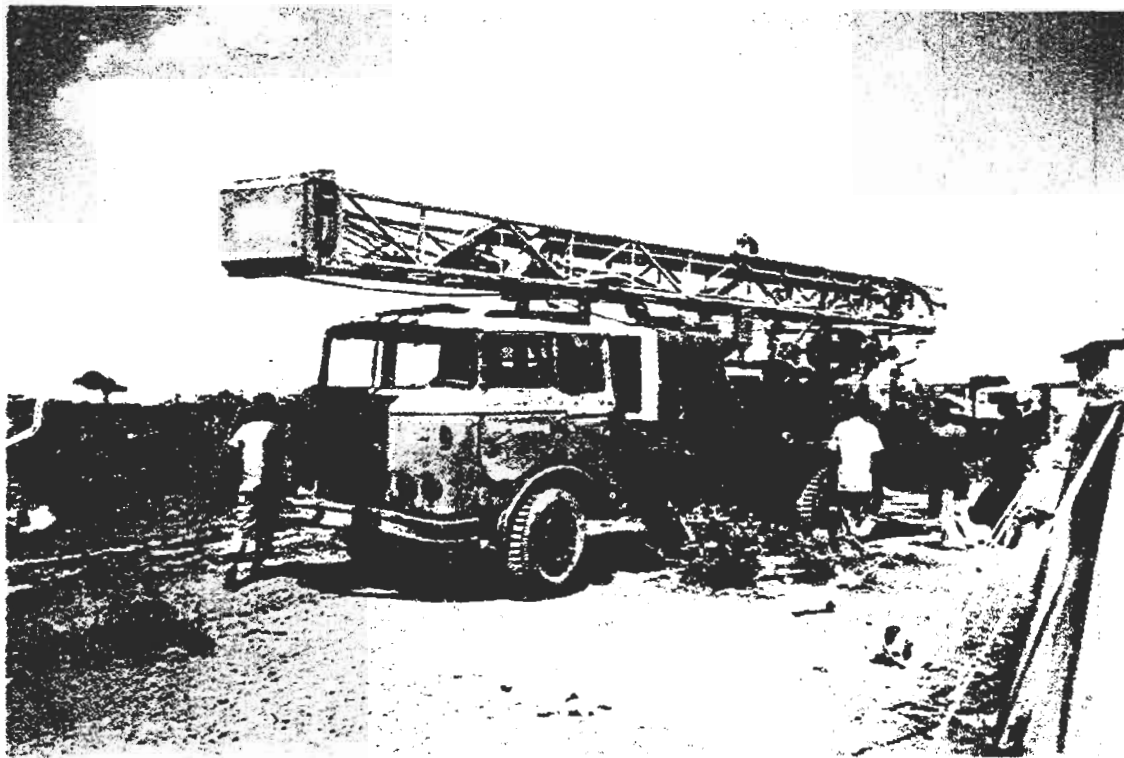

Photo 4.

Appendix

MAPS

1

SOMALIA

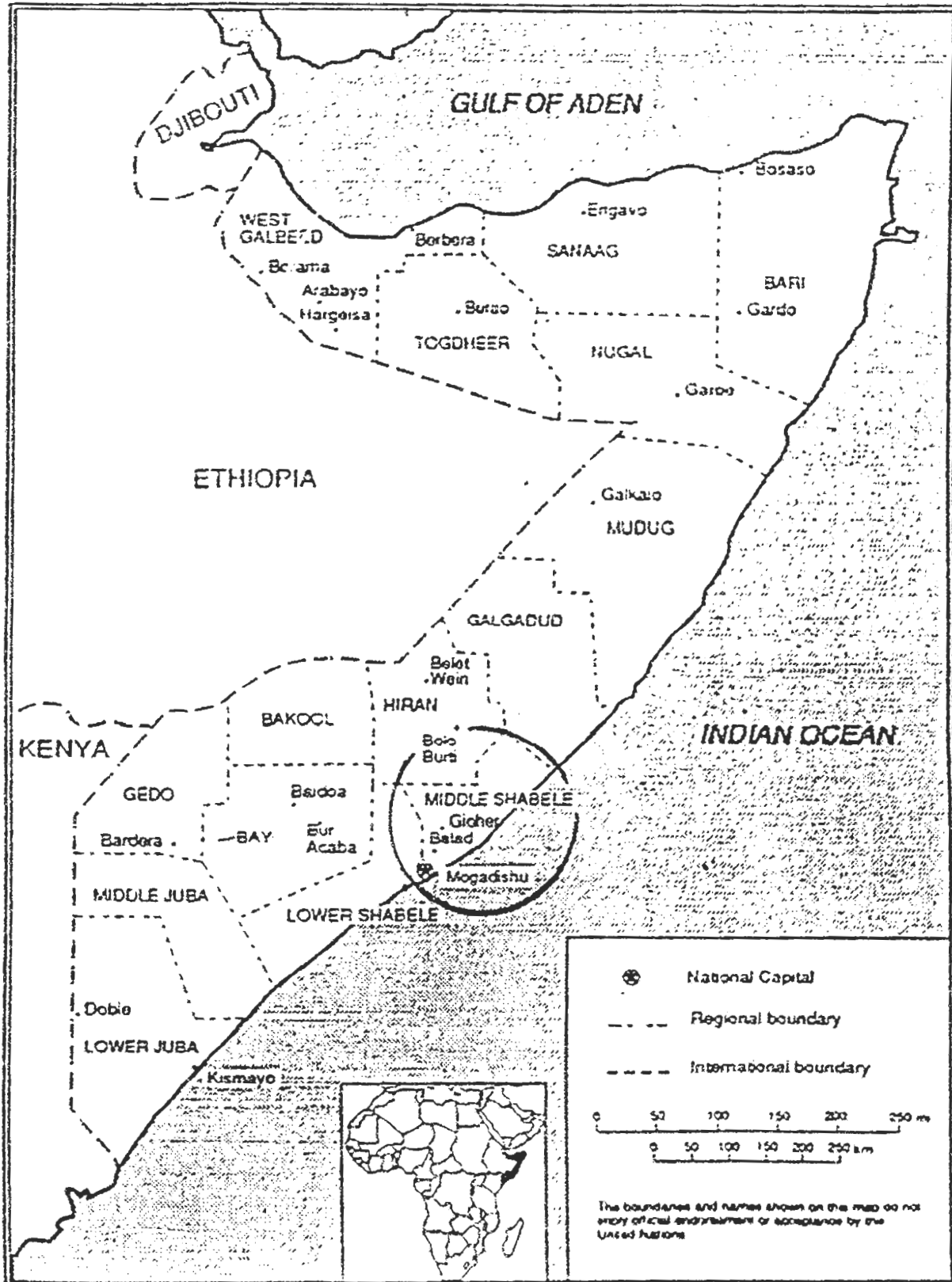

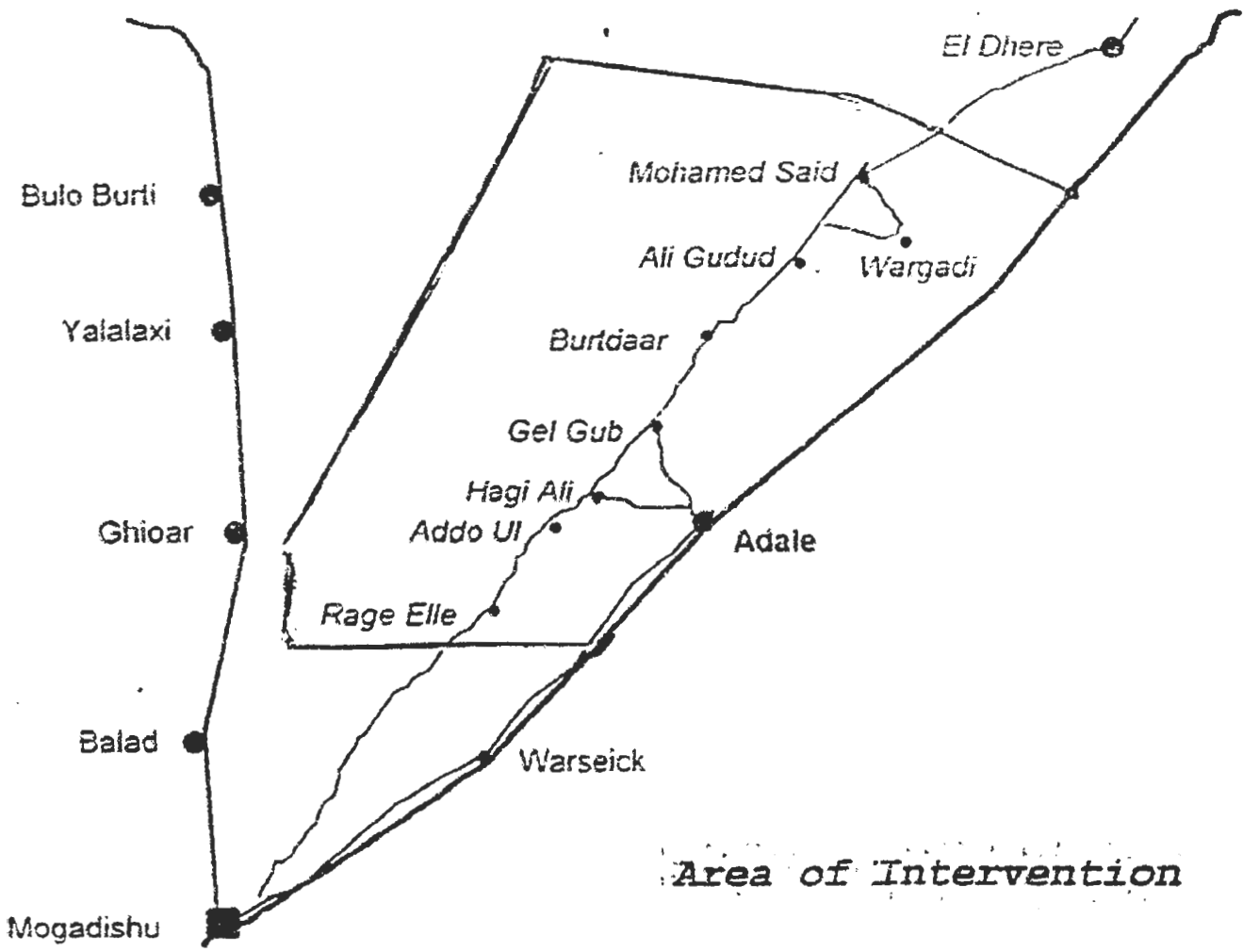

Area of Intervention



17